

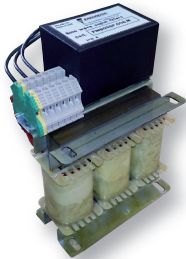

Sine wave filter with excellent attenuation for variable frequency drive applications

Datasheet 3/2017

APPROVALS:

FIN905SF.(005 - 045).M
FEATURES

- Rated current from 5 to 880A
- Very compact size
- Available in Nema 1 or Nema 3R enclosure

BENEFITS

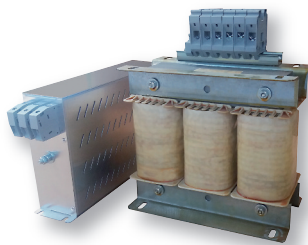
- Low power loss with frequency output up to 10 kHz
- No ventilation required
- Excellent performance versus frequency and current
- Available in open frame or enclosure

FIN905SF.(060 - 180).M
MARKETS

- Long cable applications - 2.500m
- Process plants
- Water treatment
- Agriculture
- Variable frequency drives

ORDERING CODE

FIN905SF	.100	.M	-N1
Model	Current (A)	Connection	Enclosure
		M = Terminal	N1 = Nema 1 (IP20)
		V = Screws	N3R = Nema 3R (IP54)
		B = Bus bar	

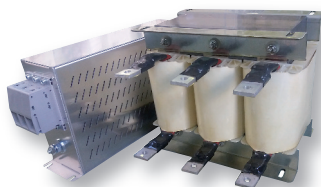
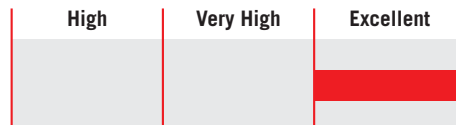
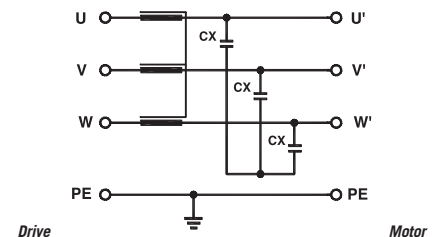
FIN905SF.(260 - 410).B
ATTENUATION INDICATOR

ELECTRIC DIAGRAM

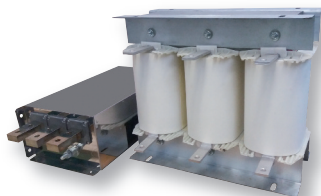
TECHNICAL SPECIFICATIONS

Nominal voltage	0 / 600 Vac
Output frequency	0 – 60 Hz
Rated current	5 to 880A
VFD carrier frequency	From 4 KHz to 12 KHz, see table
Ambient temperature	70°C
Altitude	1000 m
Relative humidity	<95% no condensation
Overload capability	4 x Rated Current (Switch ON) 2 x In 10 seconds 1.5 x In 10 minutes
IP Protection	IP20 up to 180A IP00 over 260A
Optional	Enclosure, fan

FIN905SF.(480 - 880).B

ELECTRICAL CHARACTERISTICS

FIN905SF	Rated Current 40°C	Rated Current 50°C	Min. Switch Freq. (kHz)	Power Loss (W)
.005.M	5	4	4	67
.008.M	8	7	4	79
.010.M	10	8	4	88
.016.M	16	14	4	116
.025.M	25	21	4	151
.036.M	36	30	4	175
.048.M	48	39	4	250
.060.M	60	50	4	282
.075.M	75	60	4	340
.115.M	115	95	4	575
.180.M	180	145	4	695

FIN905SF	Rated Current 40°C	Rated Current 50°C	Min. Switch Freq. (kHz)	Power Loss (W)
.260.B	260	205	4	895
.320.M	320	290	4	950
.410.M	410	350	6	1170
.480.M	480	420	6	1390
.660.M	660	580	6	2050
.750.M	750	650	6	2900
.880.M	880	750	6	3450

CONNECTIONS

LINE			PE
Solid Cable (mm ²)	Stranded Cable (mm ²)	Terminal Block Torque (Nm)	Torque (Nm)
0.2-10	0.2-6	1.2	1.2
0.2-10	0.2-6	1.2	1.2
0.2-10	0.2-6	1.2	1.2
0.2-10	0.2-6	1.2	1.2
0.2-10	0.2-6	1.8	1.8
0.2-10	0.2-6	1.8	1.8
6-35	4-25	4.5	4.5
6-35	4-25	4.5	4.5
10-50	10-50	4	4
39-95	35-95	20.0	20.0

LINE			PE
Solid Cable (mm ²)	Stranded Cable (mm ²)	Terminal Block Torque (Nm)	Torque (Nm)
M8	14	M10	18
M8	14	M10	18
M8	14	M10	18
M12	20	M10	18
M12	20	M10	18
M12	20	M10	18
M12	20	M10	18

TYPICAL MEASUREMENT

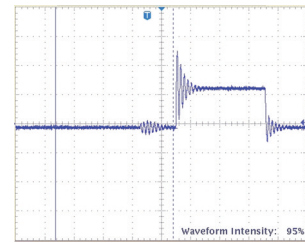

Standard waveform measured when the motor is controlled by VFD drive.

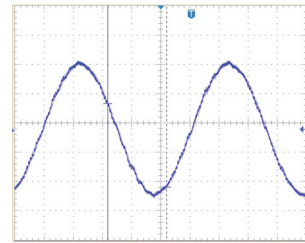

Standard waveform measured when Enerdoor sine wave filter is installed on motor controlled by VFD drive.

MECHANICAL DIMENSIONS mm

FIN905SF	A	B	C	D	E	F	G	H Ø	Weight Kg.	Case
005.M	180	90	156	150	60	116	235	8	2	1
008.M	180	90	156	150	60	116	235	8	2	1
010.M	180	90	156	150	60	116	235	8	3	1
016.M	240	130	210	210	95	165	290	8	3	1
025.M	240	130	210	210	95	165	290	8	3	1
036.M	240	130	210	210	95	165	290	8	5	2
.048.M	240	130	210	210	95	165	290	8	5	2

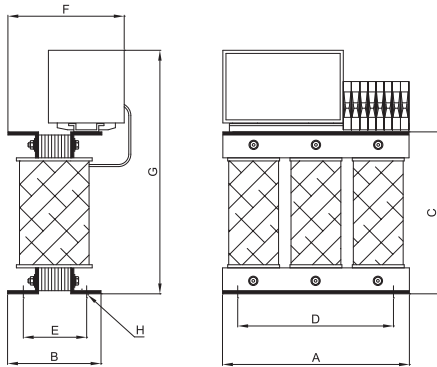
CASE 1, 2

FIN905SF	A	B	C	D	E	F	G	H	I	L	N	P	V	d	Weight Kg.	Case
.060.M	300	165	260	260	110	8	5	332	260	100	120	135	180	M5	3	3
.075.M	360	174	305	260	120	8	5	377	293	100	120	135	180	M5	3	3
.115.M	360	203	310	260	145	8	5	400	389	130	205	220	260	M5	4	4
.180.M	360	230	310	260	165	8	5	400	389	130	205	220	260	M5	4	4

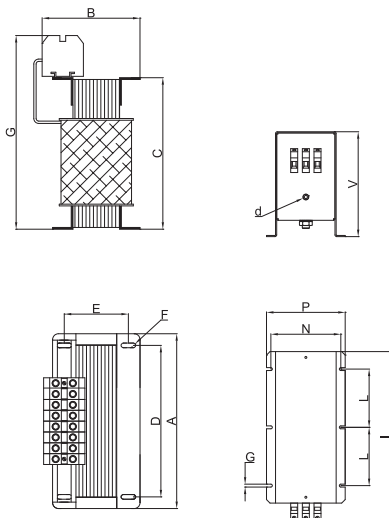
CASE 3, 4

MECHANICAL DIMENSIONS mm

FIN905SF	A	B	C	D	E	F	G	H	I	L	N	P	V	d	S	Weight Kg.	Case
.260.B	480	280	410	360	230	8	30	5	400	130	290	305	260	M5	-	132	5
.320.B	480	300	410	360	230	8	40	5	400	130	290	305	260	M5	-	163	5
.410.B	480	340	410	360	230	10	60	5	400	130	290	305	260	M5	-	188	5
.480.B	480	360	410	360	230	10	60	5	660	620	245	292	260	M5	25x10	208	6
.660.B	600	370	510	380	240	10	60	5	660	620	245	292	260	M5	25x10	309	6
.750.B	600	390	510	380	240	10	80	5	830	750	245	292	260	M5	25x10	356	6
.880.B	600	370	570	380	240	10	80	5	830	750	245	292	260	M5	25x10	351	6

CASE 5

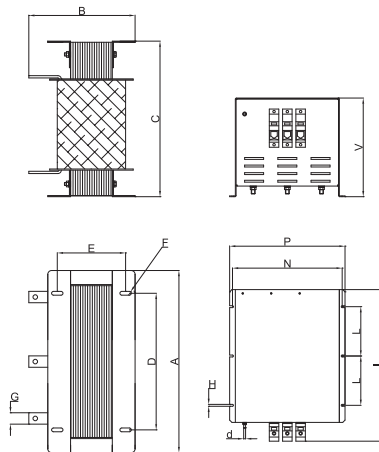

CASE 6

