

Automation Soft-Starters

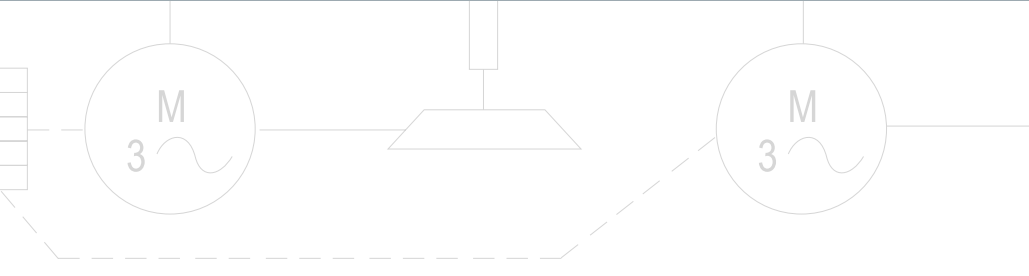

Soft-Starters

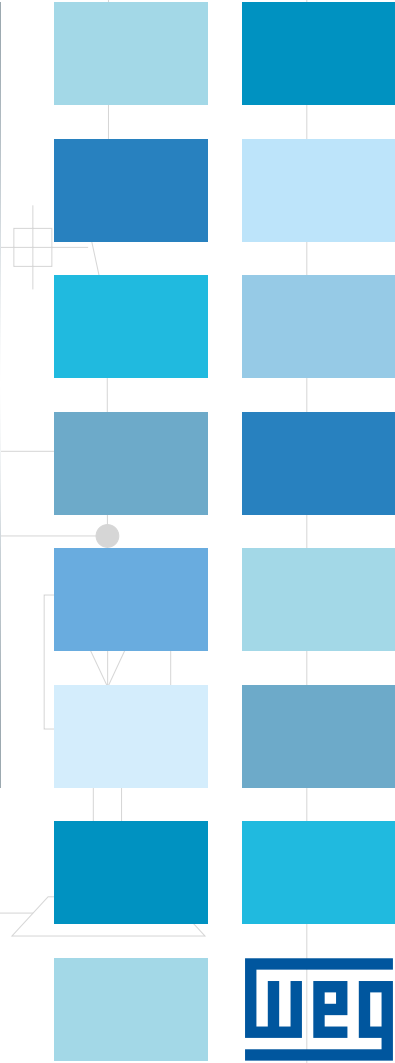
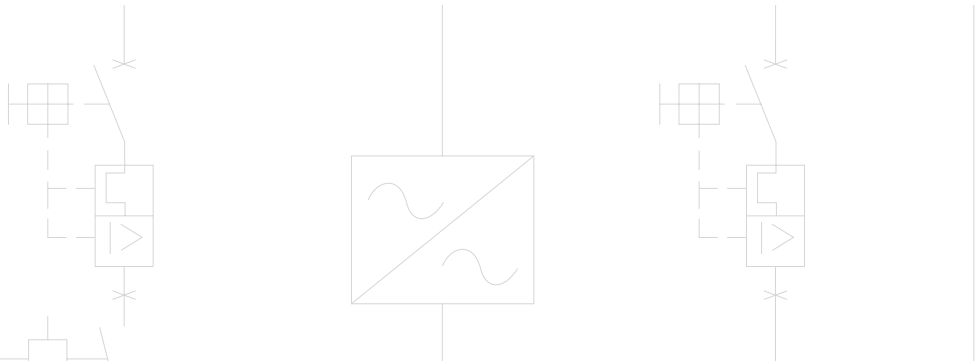

Soft-starters are static starters that accelerate, decelerate and protect three-phase induction motors. The control of the voltage applied to the motor by means of adjustments to the firing angle of thyristors allows the soft-starter to start and stop an electric motor smoothly. With adequate adjustments of the variables, the torque produced is adjusted to the needs of the load, so that the required current is going to be the lowest possible for the starting procedure.

Designed for exclusively industrial or professional use WEG soft-starters are micro processed, fully digital, designed to ensure the best start and stop performance of induction motors, presenting itself as a complete and low-cost solution. The human-machine interface allows easy adjustment of the parameters which helps on the set up and operation. The soft-starter line is top-notch in motor starting and stopping with features that allow the starting, stopping and protection of electric motors in an easy and efficient manner.



Comparison of electric motor start-up methods

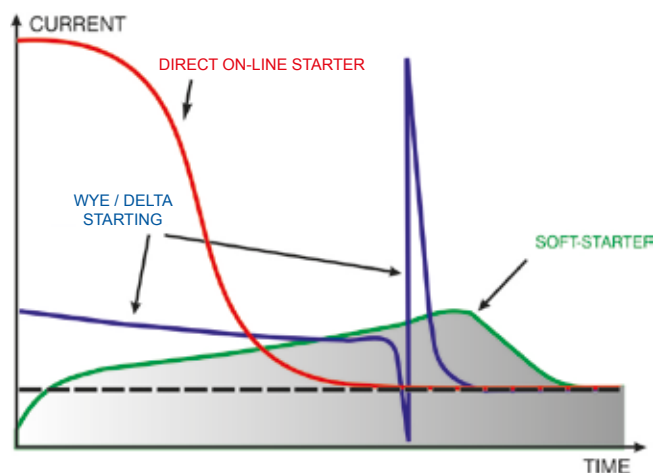

SSW05

The SSW05 Plus Micro Soft-Starters, with DSP control (Digital Signal Processor) have been designed to supply excellent performance during start and stop of electric motors with an excellent cost effectiveness ratio. The Operator Interface allows easy parameter setting, simplifying the start-up and operation activities. The SSW05 Plus Micro Soft-Starters are compact, optimizing space in electrical panels. The SSW05 Plus already incorporates protection for the driven motor.

Benefits

- Reduction of stress on couplings and other transmission devices during start (gear boxes, sheaves)
- Extended lifetime of motor and mechanical components due to reduced mechanical stress
- Easy operation, programming and maintenance
- Simple electrical wiring
- Built-in bypass providing size reduction and energy saving
- Operation in ambient up to 55 °C (122 °F)

Applications

- Bladed vacuum pumps
- Centrifugal pumps
- Screw compressor (relief start)
- Axial fans (low inertia and low load)

Certifications



SSW05 Wiring Diagram

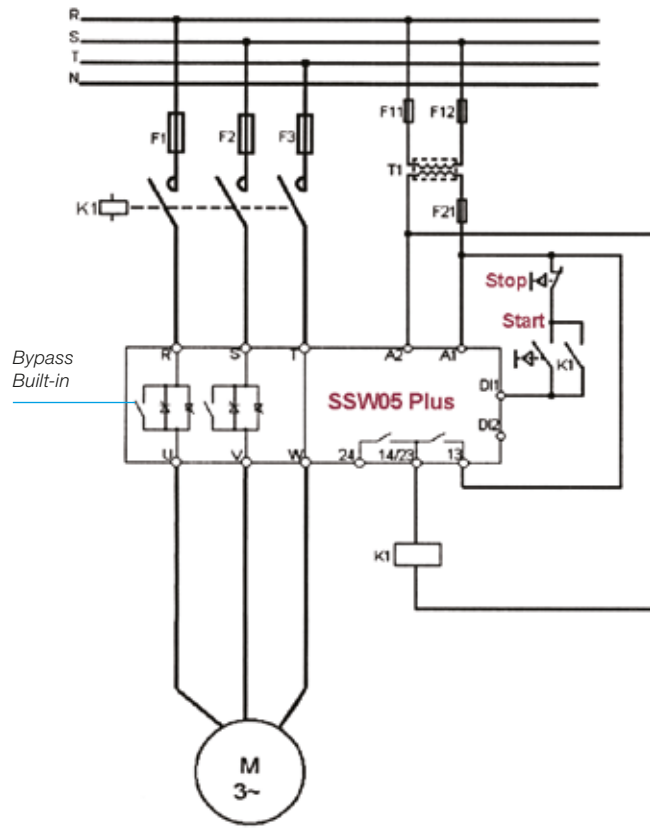

Settings and Indications

Dip switch to enable/disable the motor protections

LEDs to indicate fault trips

LEDs to indicate the starter status

Potentiometers for pedestal voltage, acceleration/deceleration time and motor current settings.

Output to motor

Three phase power supply

Electronic power supply and digital inputs



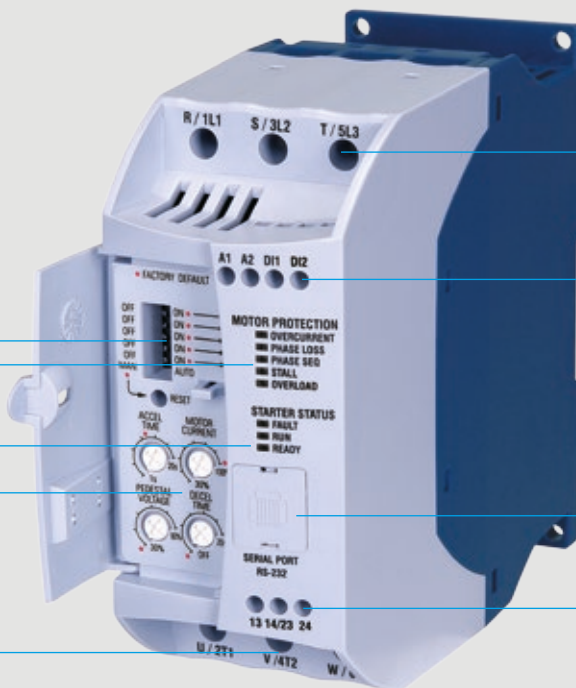

Serial or remote HMI connector

Relay outputs



SSW05 - Keypad

Remote Human-Machine Interface for remote operation on panel door or machine console. The copy function added to the keypad allows for loading of same parameter setting from one soft-starter to another. It gives reliability for applications where the same parameters settings is desired for more than one soft-staters.

-  Start the soft-starter
-  Stop the soft-starter. Resets the soft-starter after a fault trip has occurred
-  Scroll up parameters or parameter value
-  Scroll down parameters or parameter value
-  Parameter content access/escape/enter



Model	Model
CAB-RS-1	1 m cable for serial remote HMI
CAB-RS-2	2 m cable for serial remote HMI
CAB-RS-3	3 m cable for serial remote HMI
CAB-RS-5	5 m cable for serial remote HMI
CAB-RS-7.5	7.5 m cable for serial remote HMI
CAB-RS-10	10 m cable for serial remote HMI
HMI-SSW05-RS	Remote HMI for CAB-RS cable up to 3 m

SuperDrive - Software

Windows-based software for setting parameters, control and monitoring SSW05 soft-starters.

It allows setting parameters up on-line directly in the soft-starters and off-line programming in the software.

Possibility to store user parameters files from installed SSW05 soft-starters.

The communication between the soft-starter and the computer is provided through RS232 serial interface.



SSW05 - Models



SSW05 - Drive Ratings

The tables below present the expected motor power for each soft-starter model under light load application (e.g.: centrifugal pump). However, for the proper selection of soft-starters, please use the SDW software.

Use the motor power ratings below only as a guidance. Motor rated currents may vary with speed and manufacturer.

IEC motor powers are based on WEG 4-pole motors; NEMA motor powers are based on NEC table 430-150.

Motor Voltages Between 220 V and 460 V

Model	Output current	IEC - 50 Hz		IEC - 60 Hz		NEMA - 60 Hz	
		220 V 230 V	380 V 415 V	220 V 230 V	440 V 460 V	230 V	460 V
		A	kW	kW	HP	HP	HP
SSW050003T2246	3	0.55	1.1	1	1.5	0.5	1.5
SSW050010T2246	10	2.2	4	3	7.5	3	5
SSW050016T2246	16	4	7.5	5	10	5	10
SSW050023T2246	23	5.5	11	7.5	15	7.5	15
SSW050030T2246	30	7.5	15	10	20	10	20
SSW050045T2246	45	11	22	15	30	15	30
SSW050060T2246	60	15	30	20	40	20	40
SSW050085T2246	85	22	45	30	60	30	60

Motor Voltages Between 525 V and 575 V

Model	Output current	IEC	NEMA
		50 Hz 525 V	60 Hz 575 V
		kW	HP
SSW050003T4657	3	1.5	2
SSW050010T4657	10	5.5	7.5
SSW050016T4657	16	9.2	10
SSW050023T4657	23	15	20
SSW050030T4657	30	18.5	25
SSW050045T4657	45	30	40
SSW050060T4657	60	37	50
SSW050085T4657	85	55	75

SSW05 - Dimensions and Weight

Model	Frame size	Dimensions mm (in)			Weight kg (lb)	Degree of protection	Inside delta (6 cables) connection	Internal bypass
		H	W	D				
SSW050003T2246	1	130 (5.12)	59 (2.32)	145 (5.71)	0.74 (1.63)	IP00	No	Yes
SSW050010T2246								
SSW050016T2246								
SSW050023T2246								
SSW050030T2246								
SSW050045T2246	2	185 (7.28)	79 (3.11)	172 (2.79)	1.67 (3.68)	IP00	No	Yes
SSW050060T2246								
SSW050085T2246								
SSW050003T4657	1	130 (5.12)	59 (2.32)	145 (5.71)	0.74 (1.63)	IP00	No	Yes
SSW050010T4657								
SSW050016T4657								
SSW050023T4657								
SSW050030T4657								
SSW050045T4657	2	185 (7.28)	79 (3.11)	172 (2.79)	1.67 (3.68)	IP00	No	Yes
SSW050060T4657								
SSW050085T4657								

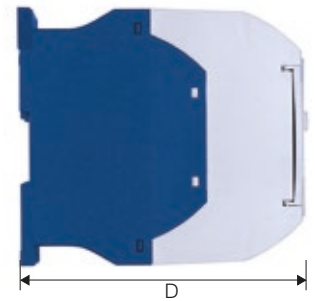

Mechanical Mounting

Size	Width W (mm)		Height H		Depth D (mm)	Mounting A (mm)	Mounting B (mm)	Mounting C (mm)	Mounting
	W	Wa	H	Ha					
1	59	60.4	130	130.7	145	51	122	61	Bold M4/Rail
2	79	80.4	185	185.7	172	71	177	99	Bold M4/Rail

Note: Wa, Ha, Mounting (only for setting with screw).

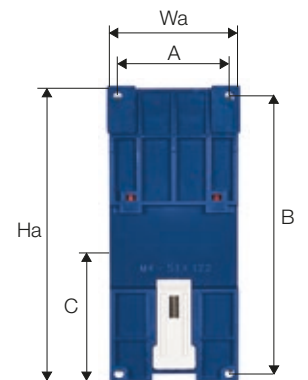

SSW05 Plus - Technical Data

Power supply	Voltage	220 - 460 V ac (+10%, -15%) 460 - 575 V ac (+10%, -15%)
	Frequency	50 / 60 Hz
	Electronic supply	Switched mode power supply (90 - 250 V ac)
	Enclosure	Degree of protection
Control	Method	Motor voltage variation
	CPU	DSP microcontroller
Starting duty cycle	Standard	300% (3 x Inom.) during 10s, 4 starts per hour
Inputs	Digital	01 input for starting and stopping
		01 input for error reset
Outputs	Digital	01 relay output for full voltage indication (bypass)
		01 relay output for operation indication
Communication	Serial interface	RS232C
Safety	Protections	Motor overload
		Phase sequency
		Phase loss
		Locked rotor
		SCRs overload
		Overcurrent
Internal fault (watchdog)		
Functions	Starting voltage	30 - 80% of the rated voltage
Resources	Programmable acceleration ramp	1 - 20s
	Programmable deceleration ramp	Off - 20s
	Motor rated current and soft-starter rated current ration	30 - 100%
Ambient	Temperature	0...55 °C - standard operation at rated current
	Humidity	5...90% non condensing
	Altitude	0...1,000 m (3,300 ft) - standard operation at rated current 1,000...4,000 m - with current derating (1%/ 100 m (328 ft) above 1,000 m (13,300 ft))
Finishing	Colour	Frost gray (cover) and blue (base)
Installation	Fastening	Fastening by bolts or assembling on DIN 35 mm rail
Conformities / standards	Safety	UL 508 Standard - Industrial Control Equipment / IRAM
	Low voltage	IEC 60947-4-2
	EMC	EMC Directive 89 / 336 / EEC - Industrial Environment

WEG Soft-Starters - Selection and Simulation Software - SDW

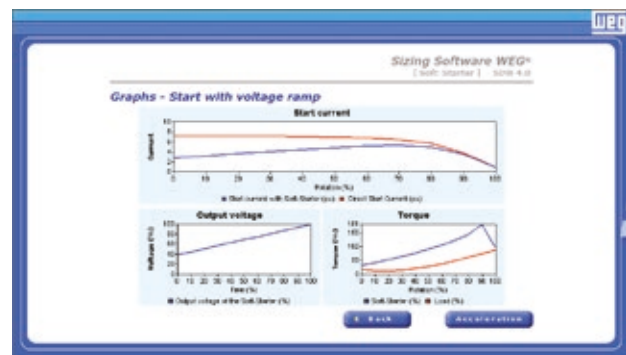

The SDW Software will find the suitable soft-starter for your application, using the WEG motor database. The SDW simulates the start-up and show acceleration graphs with the selected soft-starter.

Free SDW software on our site
www.weg.net

SSW05 - Ordering Code Information

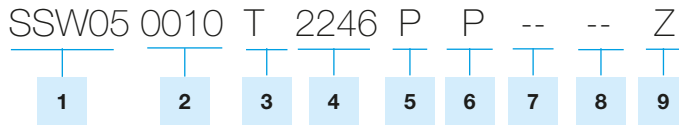

1 - Soft-starter line SSW05

2 - Rated output current:

0003 = 3 A
 0010 = 10 A
 0016 = 16 A
 0023 = 23 A
 0030 = 30 A
 0045 = 45 A
 0060 = 60 A
 0085 = 85 A

3 - Input power supply voltage: T= three-phase

4 - Power supply voltage: 2246 = 220...460 V
 4657 = 460...575 V

5 - Product manual language: P = portuguese
 E = english
 S = spanish
 G = german

6 - Product version

P = plus

7 - Special hardware

Blank = standard (not available)
 Hx = optional version x (H1...Hn)

8 - Special software

Blank = standard (not available)
 Sx = optional version x (S1...Sn)

9 - Code end

Z = end of coding



SSW06

WEG SSW06 series soft-starters are micro-processor controlled and designed to start and stop induction motors. Excellent acceleration and deceleration control is achieved with an optimized cost to benefit ratio.

The HMI allows easy programming during commissioning and operation. The built-in Pump Control function gives optimized pre-set pump application parameters, avoiding Water Hammer. The SSW06 series were designed to heavy duty and high performance applications and includes a special torque control function to smoothly start and stop induction motors.



Certifications



Benefits

- 32 bits RISC high performance microcontroller
- Electronic motor protection
- Removable Human Machine interface with double display (LED/LCD)
- Fully programmable control methods
- Totally flexible torque control
- Kick start function for high break-away torque
- Pump control function for intelligent control of pumping systems
- Avoids water hammer in pumps
- Current peaks limits on the power supply
- Voltage drop limits during starting
- Voltage Range (220 to 575 V ac and 575 to 690 V ac)
- The control board power supply has EMC filter (94 to 253 V ac)
- Built-in bypass up 820 A, providing size reduction and energy saving
- Backup memory of motor protection I²t thermal image
- Voltage and current unbalance protection
- Over/under voltage and current protection
- SoftPLC built-in
- USB connection for communication with SuperDrive and WLP software
- Emergency start
- JOG function allows slow speed in both directions without auxiliary contactors
- Three braking methods used when fast stops are necessary
- Input for motor PTC
- Reduction of mechanical stress
- Reduction of stress over couplings and transmission devices (gearboxes, sheaves, belts, etc.)
- Increases the lifetime of the motor and mechanical equipment of the driven machine
- Easy operation, programming and maintenance via keypad
- Simplified electrical installation
- Oriented start-up
- Possibility for standard three leads or inside delta size cable connection
- All protections and function available for both types of connection
- Serial or Fieldbus communication errors protection
- Operational environment up to 55 °C (without current reduction) for model range 10 A to 820 A and up to 40 °C (without current reduction) for model range 950 A to 1,400 A
- International certifications such as IRAM, C-Tick, UL, cUL, Gost and CE

SSW06 - Applications



Ceramic

- Fans / exhaust fans
- Dryers / furnaces
- Ball mills / hammer mills
- Roller tables
- Converyor belts

Wood

- Slicing machine
- Polishing machine
- Cutting machines
- Wood chippers
- Saw and plains

Chemical and Petrochemical

- Fans / exhaust fans
- Centrifugal pumps
- Dosing / process pumps
- Centrifugal pumps
- Agitators / mixers
- Compressors
- Soap extruders

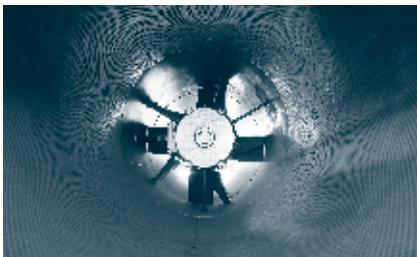

Pulp and Paper

- Dosing pumps
- Process pumps
- Fans / exhaust fans
- Agitators / mixers
- Rotatory filters
- Rotatory kilns
- Scrap conveyor
- Papers refiners
- Calenders
- Coaters



Food and Ration

- Dosing / process pumps
- Fans / exhaust fans
- Agitators / mixers
- Dryers / furnaces
- Pellet mills
- Hoist / monorails

Material Handling

- Conveyors / belts / chains
- Roller tables
- Monorails / hoist
- Escalators
- Baggage conveyors (airports)

Juice and Beverages

- Centrifugal pumps
- Agitators / mixers
- Roller tables
- Conveyor belts
- Bottling lines



Glasses

- Fans / exhaust fans
- Bottle manufacturing machine
- Roller tables
- Converyor belts

Textile

- Agitators / mixers
- Dryers / washing machines



Plastic and Rubber

- Extruding machines
- Injection & blow molding
- Mixers
- Calenders
- Grinders

Cement and Mining

- Dosing / process pumps
- Sifting machines / rotating tables
- Dynamic graders
- Conveyor belts
- Dosing machines

Sugar and Alcohol

- Fans / exhaust fans
- Process pumps
- Conveyor belts



Waste Water Treatment

- Axial flow pumps
- Impulsion systems

Voltage and Current Protections

Under and Over Voltage

It allows adjustment of the limits for under and over voltage protection. It is available for standard or inside delta connections to the motor.

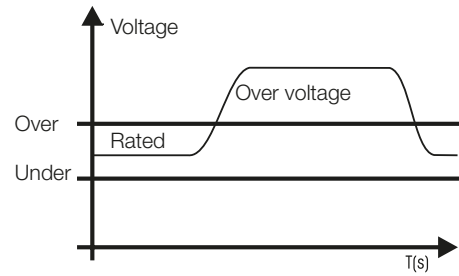
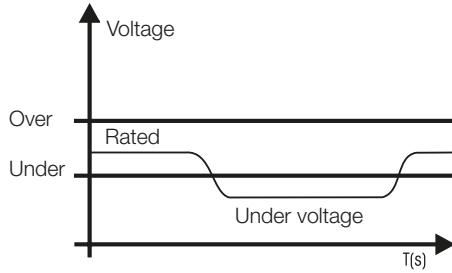

Under and Over Current

It allows adjustment of the limits for under and over current protection.

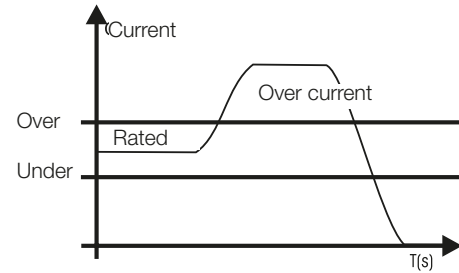
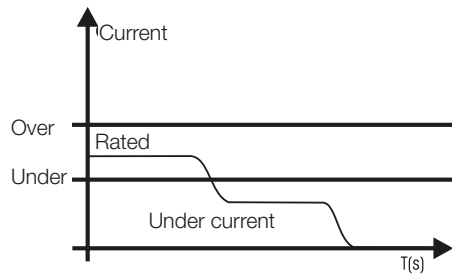

Bypass - Built-In

Built-in bypass reduces heating losses in the thyristors, providing size reduction and energy saving.

It is available in the models from 10 A up to 820 A.

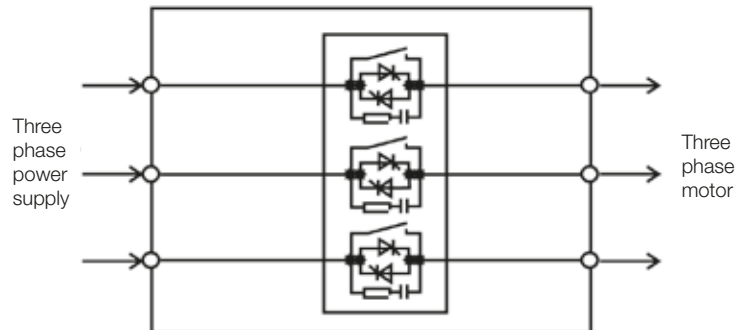

SSW06 - Main Functions

Voltage Ramp

It provides smooth acceleration and / or deceleration ramps.

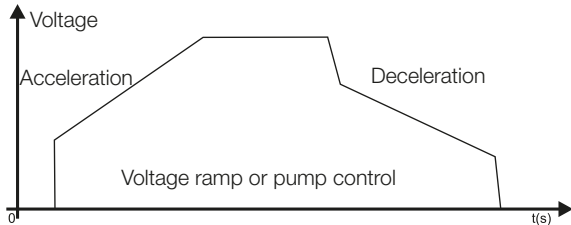

Pump Control

Pump control provides a smooth deceleration avoiding overshoots.

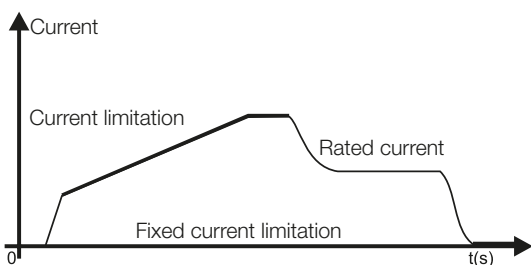

Current Limitation

It allows the torque limitation adjustment during the starting procedure based on application requirements.

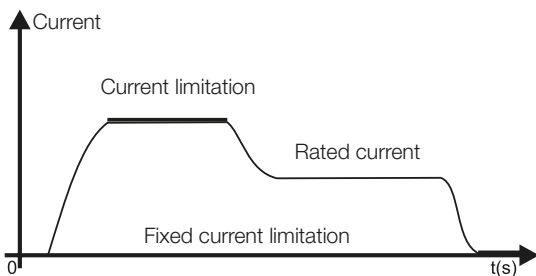

Voltage and Current Kick Starter

It provides an initial pulse of voltage or current that when applied in the motor provides an additional initial torque to the start the motor. Required for loads with high initial torque.

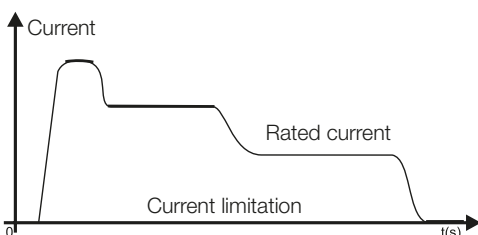
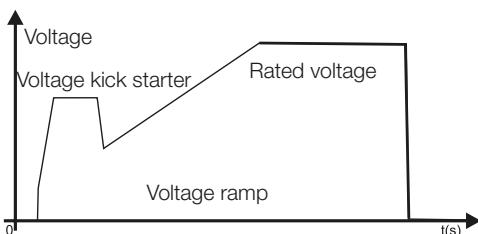

Current Ramp

It allows the adjustment of current limitation for the start. Applicable to loads with high inertia and constant torque.

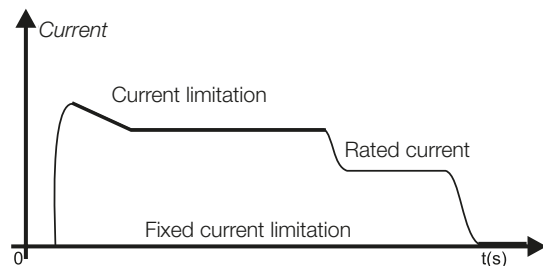
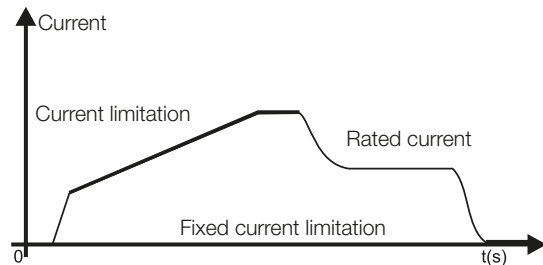

Torque Control

The SSW06 has a torque control algorithm with high performance and total flexibility for any application requirements.

It is available in both types of connection to the motor (standard / inside-delta circuit).

- 1 adjustment point - constant torque
- 2 adjustment points - linear torque ramp
- 3 adjustment points - quadratic torque ramp

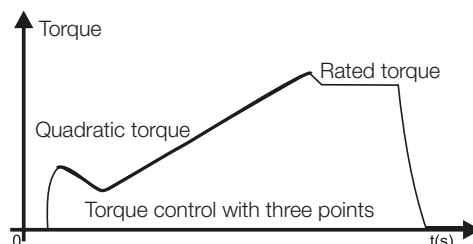
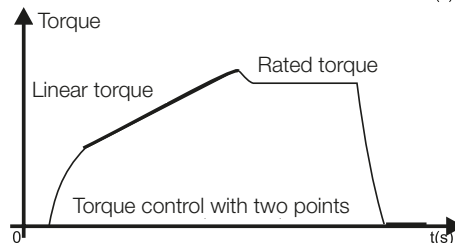
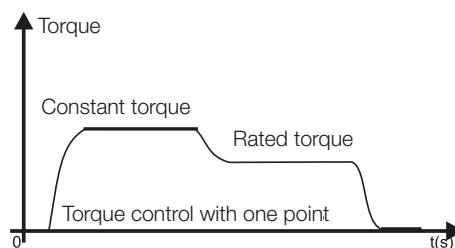

SSW06 - Keypad (HMI)

Intelligent Interface

Intelligent operation interface with double display, LED (7 segments) and LCD (2 lines of 16 characters), which allows excellent long distance visibility, with a detailed description of all parameters and messages via alphanumeric LCD display.

Selectable Language

Intelligent operation interface allows the user to choose the language for programming and display of parameters and messages in the LCD display.

The high level of hardware and software capacity of the product offers the user many options of language such as: portuguese, english, german and spanish, in order to adapt to any user in the world.

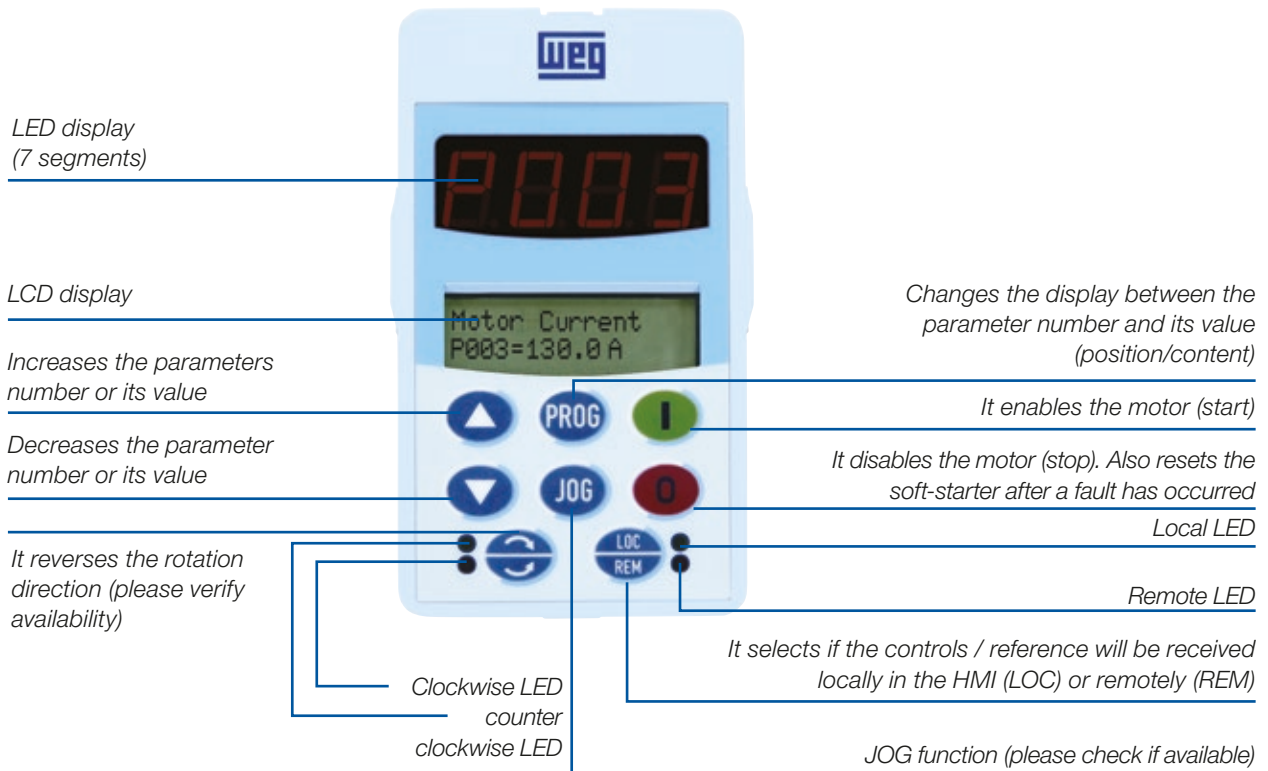

Copy Function

The intelligent interface also offers the copy function that allows copying the parameters of a soft-starter to another, bringing speed, reliability and programming repetition to similar applications.

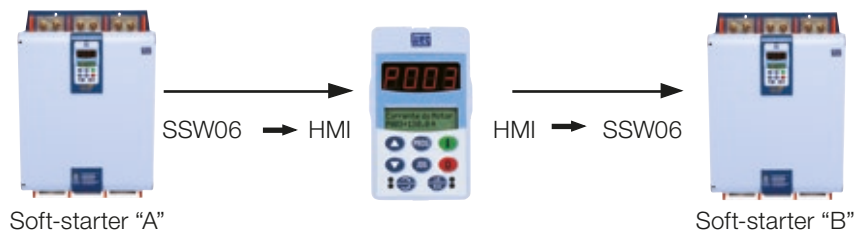

Oriented Start-Up

Soft-starters are equipment intended to start induction motors, where adaptation and response are directly related to the motor characteristics as well as the power supply.

The soft-starters from SSW06 series have a programming option specially developed to simplify the start-up, by an oriented and automatic sequence that guides the user to the sequential programming of the minimum characteristics required for adaptation of the soft-starter to the driven motor and load.

SSW06 - Fieldbus Communication

The SSW06 soft-starters can be communicated with the Fieldbus communication network through the most common standard protocols in the world, as it follows:

- Fieldbus →
- Modbus-RTU
 - Profibus-DP/DP-V1
 - DeviceNet
 - DeviceNet Acyclic
 - Ethernet IP
 - Ethernet / Modbus / TCP

Mainly intended to integrate large automation plants, communication networks offer many advantages in the supervision, monitoring and on-line control of the soft-starters, providing high performance and great operational flexibility.

To be connected to communication protocols, as Profibus, DeviceNet and Ethernet, optional modules need to be fitted in the soft-starter. For connecting the SSW06 to Modbus-RTU network the RS232 or RS485 adapter can be used.

Besides providing protection, monitoring and motor control, it is allowable the use of digital and analog I/Os of the SSW06 as a remote unit in a Profibus-DP network.

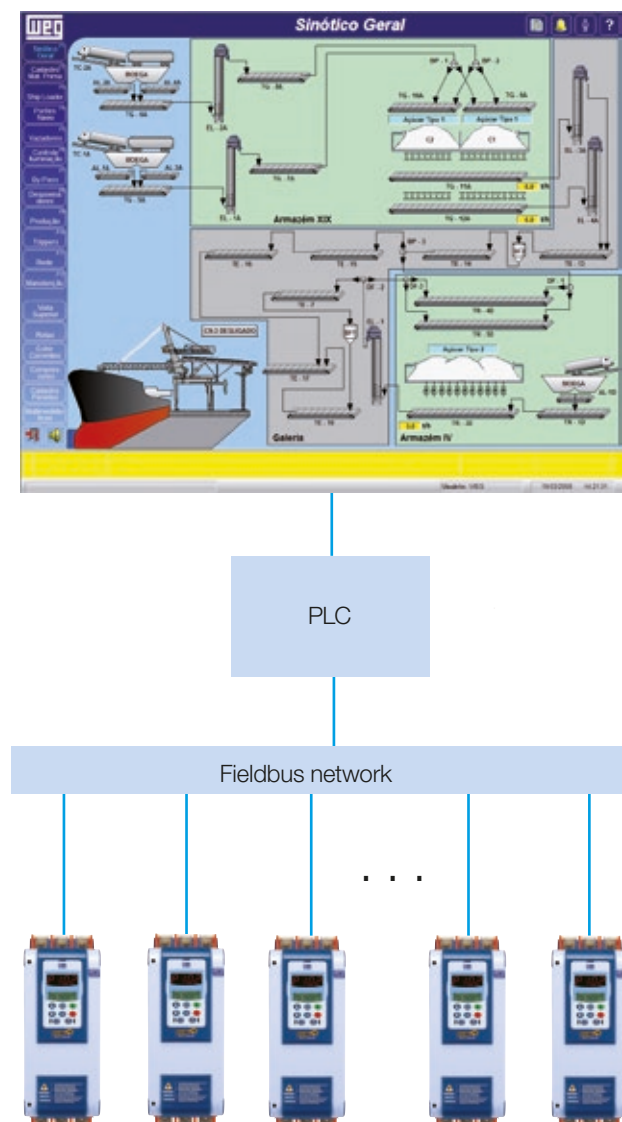

SSW06 - SuperDrive G2

Windows-based software, for SSW06 programming, control and monitoring.

- Automatic SSW06 identification
- Reads SSW06 parameters
- Writes SSW06 parameters
- On-line parameters settings
- Off-line parameters settings allow an user application to be created
- Allows documentation of the application to be created
- Easily accessible
- The Trace function provided with SuperDrive G2 version, through waveforms gives the user the possibility of status of the soft-starter at normal operating conditions as well as for troubleshooting
- A 2 m shielded USB cable is provided with the product
- On-line help
- Free software on the site www.weg.net

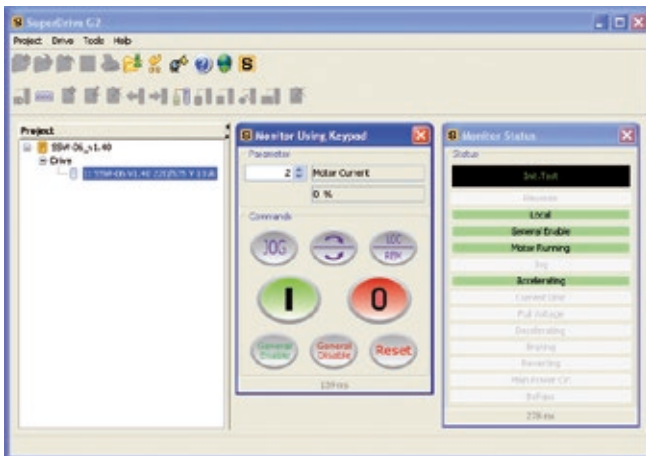
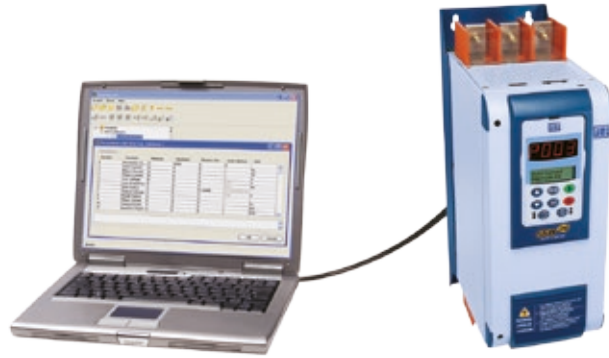

Number	Function	Minimum	Maximum	Factory Setting	User Setting	Unit
95	Fieldbus Status	0	3	0: Off	0: Off	
98	SoftPLC Status	0	4	0: Without	0: Without	
99	Allows SoftPLC	0	1	0: No	1: Yes	
101	Init. Volt Start	25	90	30	30	%
102	Start Time Ramp	1	999	20	20	s
103	Stop Down Stop	60	100	100	100	%
104	Stop Time	0	299	0	0	s
105	Final Volt. Stop	30	55	30	30	%
106	End of Start	0	1	0: For Time	0: For Time	
110	Current Limit	150	500	300	300	%
111	Init. Curr. Ramp	150	500	150	150	%
112	Time Curr. Ramp	1	99	20	20	%
120	Torque Start	1	3	1: Constant	1: Constant	
121	Init. Torque Start	10	400	30	30	%
122	End Torque Start	10	400	110	110	%
123	Min. Torque Start	10	400	27	27	%
124	Time Min. T. Start	1	99	20	20	%

Monitoring and parameterization of the list of parameters comparison to factory default easy

Integrated environment

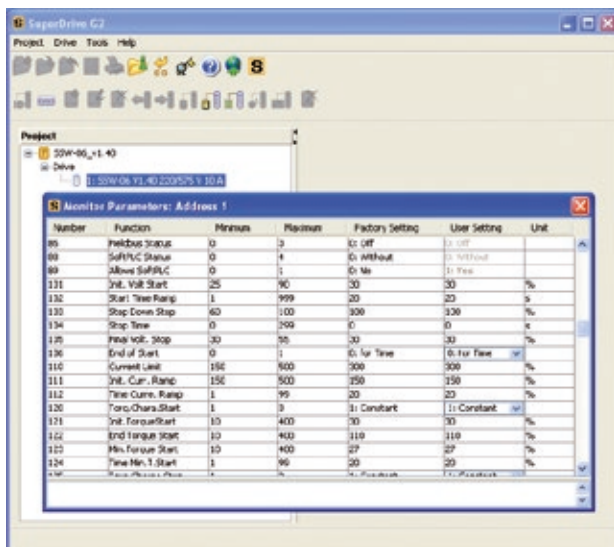

Trace function configuration in the G2 SuperDrive



Status monitoring



Monitoring and control window using virtual HMI

SSW06 - SoftPLC Function

A factory built resource that provides SSW06 with PLC functions giving flexibility to the user and allowing development of customized user application programs.

- Ladder programming language - WLP software
- Access to all inverter parameters and I/Os
- PLC, mathematical and control blocks
- Download, upload and on-line monitoring
- Memory capacity of 1 kbytes
- Allows documentation of the application to be created
- On-line help
- Free software on the site www.weg.net

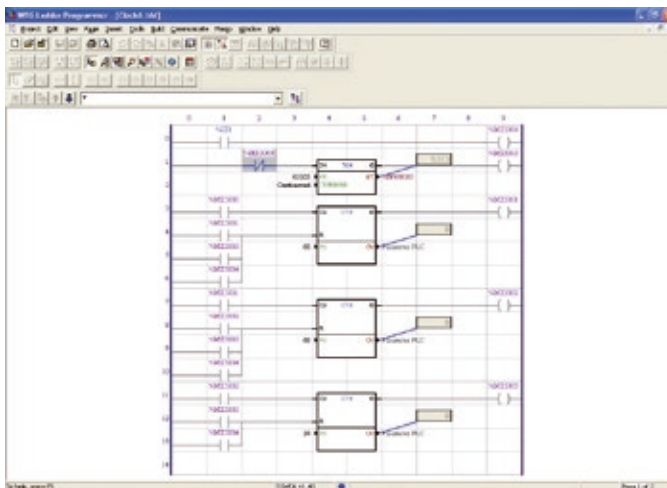
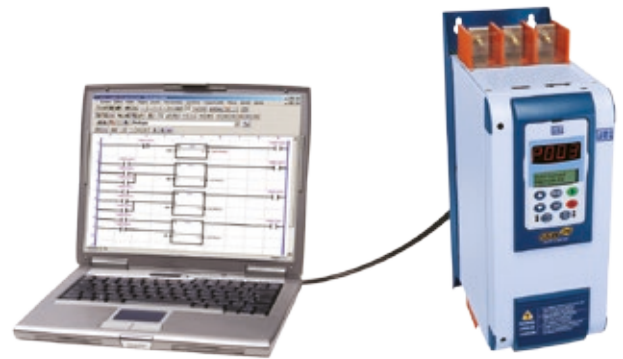

Simple and practical programming environment

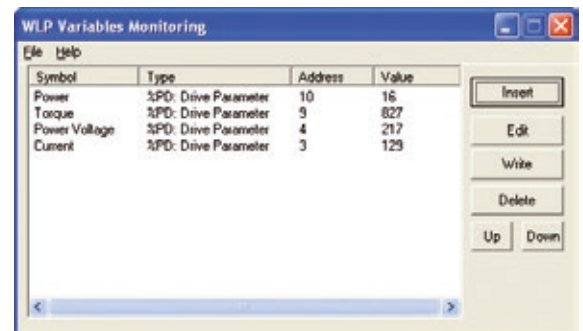

On-line monitoring

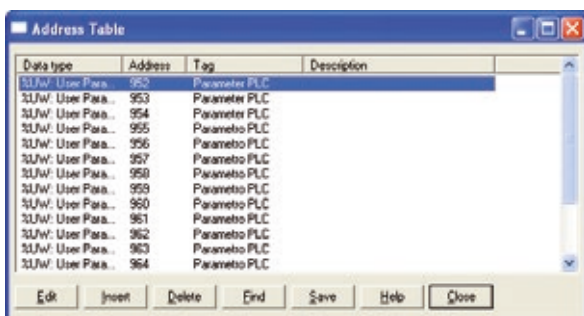

User's parameters

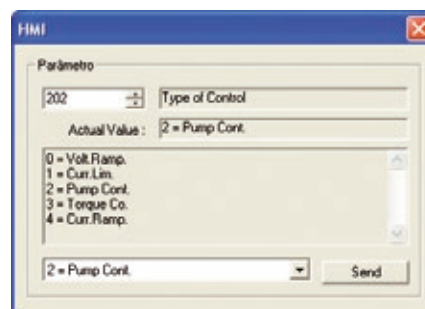

Virtual HMI for alteration of parameters



Digital input and output monitoring

SSW06 - Multimotor Application

Soft-starter multimotor control consists in starting more than one motor with the same soft-starter, reducing the cost of the motor starting system and maintenance. With SSW06 the multimotor control can be implemented in two ways.

Parallel Multimotor

- All motors are connected in parallel, starting and stopping motors simultaneously
- Soft-starter must be selected to support the amount of all motor currents
- All WEG soft-starters allow this type of application

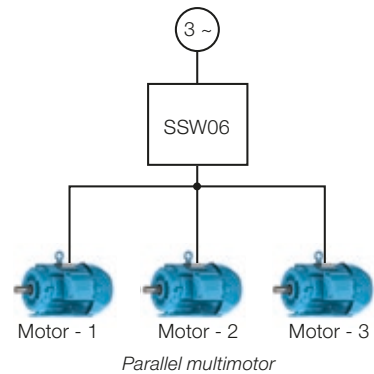

Cascade Multimotor

- Easy implementation through SoftPLC functions, thus external PLC is not required
- Using the I/Os expansion kit and auxiliary contactors the SSW06 can start and stop up to 3 motors in cascade or individually
- Able to control a multipump system using external sensors to start and stop each pump automatically

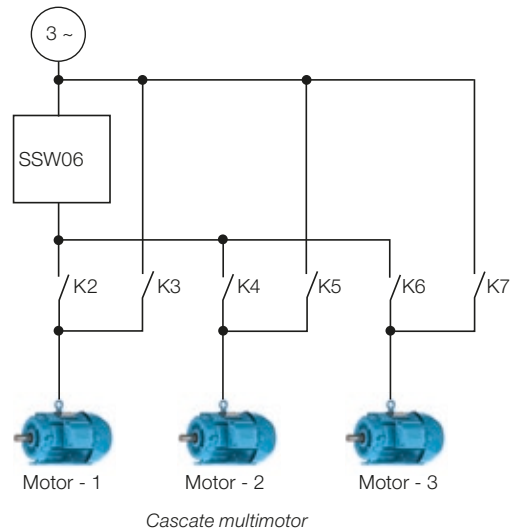

Note: please consult WEG to provide also the individual motor protections that must be implemented in both multimotor systems.

SSW06 - Accessories

Accessories	Code	Description
Human machine interface (follow the standard product)	HMI SSW06 LCD	Keypad with double display (LED and LCD) Degree of protection - IP22 Copy function
Remote keypad frame kit	KMR-SSW06	Remote mounting frame for HMI remote installation in front of panel door or in the machine console
Cables for connecting HMI to SSW06 (1, 2, 3 and 5 m)	CAB - HMI SSW06 - 1	1 m (3.3 ft) remote keypad cable
	CAB - HMI SSW06 - 2	2 m (6.6 ft) remote keypad cable
	CAB - HMI SSW06 - 3	3 m (10 ft) remote keypad cable
	CAB - HMI SSW06 - 5	5 m (16 ft) remote keypad cable
RS485 communication kit	KRS485	Enables the connection of the SSW06 to a Modbus-RTU via an isolated RS485 port
Profibus-DP communication kit	KFB-PD	Enable in SSW06 the controlling and monitoring via a Fieldbus network
Profibus-DP-PV1 communication kit	KFB-PDPV1	
DeviceNet communication kit	KFB-DN	
DeviceNet drive profile communication kit	KFB-DD	
Ethernet IP communication kit	KFB-ENIP	
IP20 kit Protection kits for power connections	KIT IP20 M2	Kit IP20 for size 2 (85 to 130 A)
	KIT IP20 M3	Kit IP20 for size 3 (170 to 205 A)
	KIT IP20 M4/M5	Kit IP20 for size 4 and 5 (255 to 604 A)
	KIT IP20 M6	Kit IP20 for size 6 (670 to 820 A)
I/Os expansion module for SoftPLC applications	KEIO - SSW06	6 isolated digital inputs 6 relay digital outputs
External current transformer (for models 255 to 1,400 A)	K-ECA	Used when external bypass is required to keep protections activated
Pt-100 temperature transducer	K-Pt-100	Optional module for motor Pt-100 connection (up to 5 sensors)

SSW06 - A Complete, Flexible and Compact Product

Power supply incoming - power input terminals

LED display 7 segments

Liquid crystal (LCD) display
2 lines of 16 characters

32 bits RISC high performance microcontroller

Network communication modules to:
Profibus-DP, DeviceNet (both optional)

Motor PTC insulated input

Six insulated programmable digital inputs

Power output terminals to the motor



Removable HMI with double display (LCD + LED), multi-language and copy function

Three programmable digital relay outputs

Interface serial RS485 Modbus-RTU (optional)

Interface serial RS232 Modbus-RTU

Control cables access

Two programmable analogue outputs

Electronic board protection fuse

SSW06 - Typical Wiring Diagrams

Standard (3 Leads)

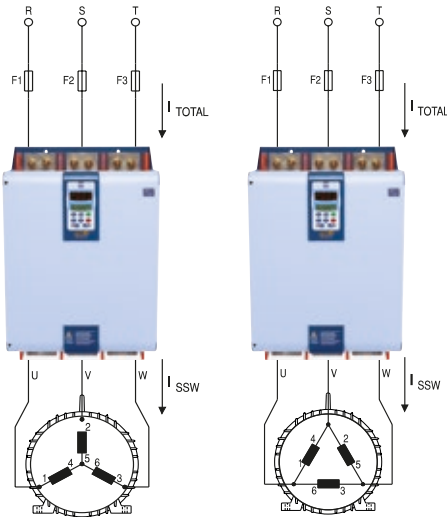

SSW06 Standard Connection

Motor in Y Motor in Δ

$$I_{\text{Soft- Starter}} = I_{\text{Full Current}}$$

Inside Delta Connection (6 Leads)

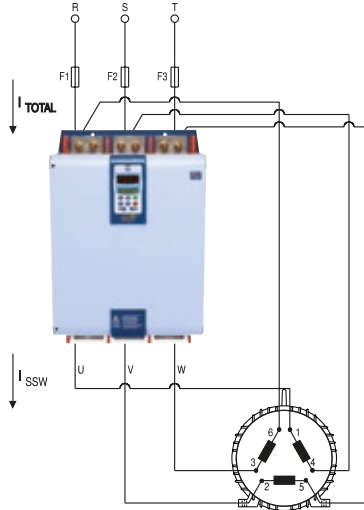

SSW06 Delta Connected

$$I_{\text{Soft- Starter}} = \frac{I_{\text{required}}}{\sqrt{3}} = 58\% \text{ of } I_{\text{required}} \text{ (after the start)}$$

$$I_{\text{Soft- Starter}} = \frac{I_{\text{required}}}{1.5} = 67\% \text{ of } I_{\text{required}} \text{ (during start)}$$

Notes: At the starting, for the same motor power, the inside delta connection (6 leads) allows for a reduction of 33% of the soft-starter current if compared to the 3 leads connection. Even when the motor is up to speed a reduction of 42% of the soft-starter current is achieved by using 6 leads connection. Basically the inside delta connection option offered by the SSW06 gives the customer alternative ways of reducing cost and size when it comes to soft-starter solutions.

A 6 leads motor is required when inside delta connection is used.

Motor	6 leads connection
220 V -Δ / 380 V-Y	220 V -Δ
380 V -Δ / 660 V-Y	380 V -Δ
440 V -Δ / 760 V-Y	440 V -Δ
575 V - Δ	575 V -Δ
220 V -Δ / 380 V- Y/	220 V -Δ
440 V -Δ / 760 V-Y	440 V -Δ

- For the same motor power, the inside delta connection (6 leads), a reduction of 42% of the soft-starter current compared to the standard connection (3 leads)
- The inside delta connection (6 leads) allows the soft-starter to start a motor 73% greater than the standard connection (3 leads)
- The Inside delta connection requires 6 leads from the soft-starter to the motor
- During the start, the motor current can be 1.5 times greater than the soft-starter one
- After the start, the motor current can be 1.73 times greater than the soft-starter

SSW06 - Drive Ratings

The tables below present the expected motor power for each soft-starter model under light load application (e.g.: centrifugal pump). However, for the proper selection of soft-starters, please use the SDW software.

Use the motor power ratings below only as a guidance. Motor rated currents may vary with speed and manufacturer.

IEC motor powers are based on WEG 4-pole motors; NEMA motor powers are based on NEC table 430-150 (ratings up to 500 HP) and on WEG 4-pole motors (ratings above 500 HP).

Inline Connection (3 leads)

Motor Voltages Between 220 V and 575 V

Model	Output current	IEC - 50 Hz			IEC - 60 Hz		NEMA - 60 Hz		
		220 V 230 V	380 V 415 V	525 V	220 V 230 V	440 V 460 V	230 V	460 V	575 V
		A	kW	kW	HP	HP	HP	HP	HP
sSSW060010T2257	10	2.2	4	5.5	3	7.5	3	5	7.5
SSW060016T2257	16	4	7.5	9.2	5	10	5	10	10
SSW060023T2257	23	5.5	11	15	7.5	15	7.5	15	20
SSW060030T2257	30	7.5	15	18.5	10	20	10	20	25
SSW060045T2257	45	11	22	30	15	30	15	30	40
SSW060060T2257	60	15	30	37	20	40	20	40	50
SSW060085T2257	85	22	45	55	30	60	30	60	75
SSW060130T2257	130	37	55	90	50	100	50	100	125
SSW060170T2257	170	45	90	110	60	125	60	125	150
SSW060205T2257	205	55	110	132	75	150	75	150	200
SSW060255T2257	255	75	132	185	100	200	100	200	250
SSW060312T2257	312	90	160	220	125	250	125	250	300
SSW060365T2257	365	110	185	250	150	300	150	300	350
SSW060412T2257	412	110	220	300	150	350	150	300	450
SSW060480T2257	480	132	250	355	200	400	200	400	500
SSW060604T2257	604	185	315	450	250	500	250	500	600
SSW060670T2257	670	200	355	500	270	550	-	600	700
SSW060820T2257	820	250	450	560	350	700	-	700	900
SSW060950T2257	950	280	500	710	400	800	-	800	1,000
SSW061100T2257	1,100	315	560	800	450	900	-	900	1,100
SSW061400T2257	1,400	400	710	1,000	550	1,250	-	1,100	1,500

Motor Voltage 690 V

Model	Output current	IEC
		50 Hz 690 V kW
SSW060045T5769	45	37
SSW060060T5769	60	55
SSW060085T5769	85	75
SSW060130T5769	130	110
SSW060170T5769	170	160
SSW060205T5769	205	185
SSW060255T5769	255	250
SSW060312T5769	312	300
SSW060365T5769	365	355
SSW060412T5769	412	400
SSW060480T5769	480	450
SSW060604T5769	604	560
SSW060670T5769	670	630
SSW060820T5769	820	800
SSW060950T5769	950	900
SSW061100T5769	1,100	1,120
SSW061400T5769	1,400	1,400

Notes: 1) The maximum power of the motors in the table have been calculated based on WEG 2 and 4 poles motors.

For motors with another polarity (Ex.: 6 or 8 poles), or another voltage and/or another motor brand please specify the soft-starter based on the motor rated current.

2) In 950 A model, the fan voltage must be specified as 110 or 220 V ac.

3) In 1,100 A and 1,400 A models, the fan voltage is always 220 V ac.

4) Ambient temperature (Ta) = 0... 55 °C is only valid for 10 A up to 820 A models, for the 950 A, 1,100 A and 1,400 A models, Ta= 0...40 °C.

5) Use the SDW software for correct sizing of the soft-starter.



SSW06 - Drive Ratings

Inside Delta Connection (6 leads)

Motor Voltages Between 220 V and 575 V

Model	Output current	IEC - 50 Hz			IEC - 60 Hz		NEMA - 60 Hz		
		220 V 230 V	380 V 415 V	525 V	220 V 230 V	440 V 460 V	230 V	460 V	575 V
		A	kW	kW	kW	HP	HP	HP	HP
sSW060010T2257	-	-	-	-	-	-	-	-	-
SSW060016T2257	-	-	-	-	-	-	-	-	-
SSW060023T2257	-	-	-	-	-	-	-	-	-
SSW060030T2257	-	-	-	-	-	-	-	-	-
SSW060045T2257	77	22	37	55	30	60	25	60	75
SSW060060T2257	103	30	55	75	40	75	30	75	100
SSW060085T2257	147	37	75	90	60	125	50	100	150
SSW060130T2257	225	55	110	160	75	175	75	150	200
SSW060170T2257	294	75	160	220	125	200	100	200	300
SSW060205T2257	355	110	185	250	150	300	125	250	350
SSW060255T2257	441	132	220	315	175	350	150	350	450
SSW060312T2257	540	160	250	400	200	450	200	450	600
SSW060365T2257	631	185	315	450	250	550	250	500	700
SSW060412T2257	713	220	370	500	300	600	-	600	800
SSW060480T2257	831	250	450	630	350	700	-	700	900
SSW060604T2257	1,046	315	560	800	450	900	-	900	1,100
SSW060670T2257	1,160	355	630	900	450	950	-	1,000	1,250
SSW060820T2257	1,420	400	800	1,000	550	1,250	-	1,250	1,500
SSW060950T2257	1,645	-	900	1,250	650	1,350	-	1,350	1,750
SSW061100T2257	1,905	-	1,000	1,400	800	1,500	-	1,500	2,000
SSW061400T2257	2,424	-	1,250	1,800	1,000	2,000	-	2,000	2,500

- Notes: 1) The maximum power of the motors in the table have been calculated based on WEG 2 and 4 poles motors.
 For motors with another polarity (Ex.: 6 or 8 poles), or another voltage and/or another motor brand please specify the soft-starter based on the motor rated current.
 2) In 950 A model, the fan voltage must be specified as 110 or 220 V ac.
 3) In 1,100 A and 1,400 A models, the fan voltage is always 220 V ac.
 4) Ambient temperature (Ta) = 0... 55 °C is only valid for 10 A up to 820 A models, for the 950 A, 1,100 A and 1,400 A models, Ta= 0...40 °C.
 5) Use the SDW Software for correct sizing of the soft-starter.

WEG Soft-Starters - Selection and Simulation Software - SDW

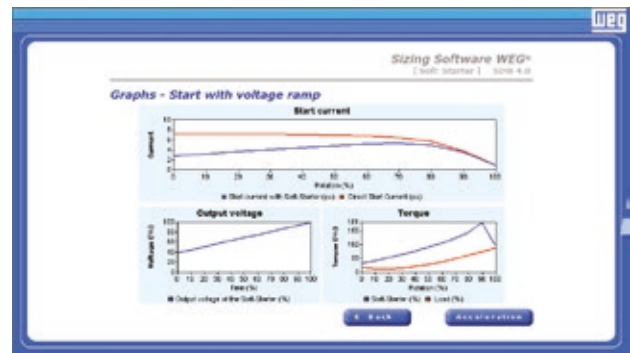

The SDW Software will find the suitable soft-starter for your application, using the WEG motor database. The SDW simulates the start-up and show acceleration graphs with the selected soft-starter.

Free SDW software on our site
www.weg.net

SSW06 - Dimensions and Weight

Model	Frame size	Dimensions mm (in)			Weight kg (lb)	Degree of protection	Inside delta (6 cables) connection	Internal bypass								
		H	W	D												
SSW060010T2257	1	256 (10.08)	132 (5.20)	182 (7.16)	3.3 (7.3)	IP20	No	Yes								
SSW060016T2257																
SSW060023T2257																
SSW060030T2257																
SSW060045T2257	2	370 (14.57)	132 (5.20)	244 (9.61)	8.5 (18.7)	IP00 (IP20 as optional)	Yes									
SSW060060T2257																
SSW060085T2257																
SSW060130T2257																
SSW060170T2257	3	440 (17.32)	223 (8.78)	278 (10.94)	18.5 (40.8)	IP00 (IP20 as optional)	Yes									
SSW060205T2257																
SSW060255T2257	4	550 (21.65)	370 (14.57)	311 (12.24)	41.5 (91.5)	IP00 (IP20 as optional)	Yes									
SSW060312T2257																
SSW060365T2257																
SSW060412T2257	5	650 (25.59)	370 (14.57)	347 (13.66)	55 (121.3)	IP00 (IP20 as optional)	Yes									
SSW060480T2257																
SSW060604T2257	6	795 (31.30)	540 (21.26)	357 (14.05)	120 (264.6)	IP00 (IP20 as optional)	Yes									
SSW060670T2257																
SSW060820T2257	7	845 (33.27)	570 (22.44)	347 (13.66)	107 (235.9)	IP00	Yes	No								
SSW060950T2257																
SSW061100T2257																
SSW061400T2257																
SSW060045T5769									2	370 (14.57)	132 (5.20)	244 (9.61)	8.5 (18.7)	IP00 (IP20 as optional)	No	Yes
SSW060060T5769																
SSW060085T5769																
SSW060130T5769																
SSW060170T5769	3	440 (17.32)	223 (8.78)	278 (10.94)	18.5 (40.8)	IP00 (IP20 as optional)	No									
SSW060205T5769																
SSW060255T5769	4	550 (21.65)	370 (14.57)	311 (12.24)	41.5 (91.5)	IP00 (IP20 as optional)	No									
SSW060312T5769																
SSW060365T5769																
SSW060412T5769	5	650 (25.59)	370 (14.57)	377 (13.66)	55 (121.3)	IP00 (IP20 as optional)	No									
SSW060480T5769																
SSW060604T5769	6	795 (31.30)	540 (21.26)	357 (14.05)	120 (264.6)	IP00 (IP20 as optional)	No									
SSW060670T5769																
SSW060820T5769	7	845 (33.27)	570 (22.44)	347 (13.66)	107 (235.9)	IP00	No	No								
SSW060950T5769																
SSW061100T5769																
SSW061400T5769																

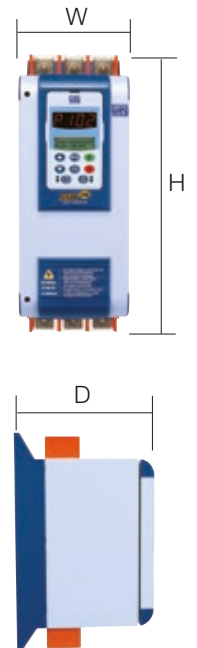

Mechanical Mounting

Model	A mm (in)	B mm (in)	C mm (in)	D mm (in)	Fixation bolt	Size
SSW060010	75 (2.95)	239 (9.40)	28 (1.10)	8.5 (0.33)	M5	1
SSW060016						
SSW060023						
SSW060030						
SSW060045	75 (2.95)	350 (13.78)	28.5 (1.12)	8.5 (0.33)	M5	2
SSW060060						
SSW060085						
SSW060130						
SSW060170	150 (5.91)	425 (16.73)	36.5 (1.44)	5.9 (0.23)	M6	3
SSW060205						
SSW060255	200 (7.87)	527.5 (20.77)	85 (3.35)	10 (0.39)	M6	4
SSW060312						
SSW060365						
SSW060412	200 (7.87)	627.5 (24.70)	85 (3.35)	10 (0.39)	M6	5
SSW060480						
SSW060604	350 (13.78)	775 (30.51)	95 (3.74)	7.5 (0.29)	M8	6
SSW060670						
SSW060820	400 (15.75)	810 (31.89)	84 (3.31)	10 (0.39)	M8	7
SSW060950						
SSW061100	500 (19.68)	1,110 (43.70)	93 (3.66)	15 (0.59)	M8	8
SSW061400						

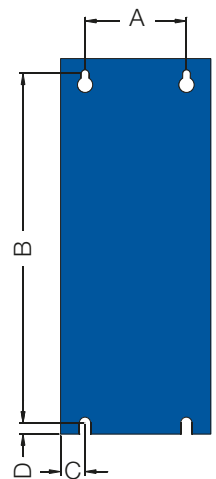

SSW06 - Mounting Clearance

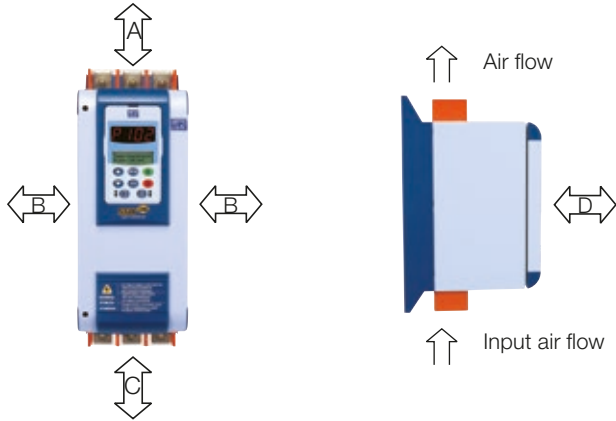

Model	A mm (in)	B mm (in)	C mm (in)	D mm (in)	Size
SSW060010	150 (5.90)	30 (1.18)	150 (5.90)	50 (1.96)	1
SSW060016					
SSW060023					
SSW060030					
SSW060045	150 (5.90)	30 (1.18)	150 (5.90)	50 (1.96)	2
SSW060060					
SSW060085					
SSW060130	150 (5.90)	30 (1.18)	150 (5.90)	50 (1.96)	3
SSW060170					
SSW060205	150 (5.90)	30 (1.18)	150 (5.90)	50 (1.96)	4
SSW060255					
SSW060312					
SSW060365	150 (5.90)	30 (1.18)	150 (5.90)	150 (1.96)	5
SSW060412					
SSW060480					
SSW060604	150 (5.90)	30 (1.18)	150 (5.90)	50 (1.96)	6
SSW060670					
SSW060820	150 (5.90)	30 (1.18)	150 (5.90)	50 (1.96)	7
SSW060950					
SSW061100	150 (5.90)	100 (1.18)	150 (5.90)	50 (1.96)	8
SSW061400					



SSW06 - Technical Data

Power supply	Power	(220 to 575) or (575 to 690) V ac (-15% to +10%)	
	Control	(110 to 230) V ac (-15% to +10%), or (94 to 253) V ac	
	Fan	Models from 255 to 820 A: 115 V ac (104 to 127) V ac / 230 V ac (207 to 253) V ac	
		Model 950 A: 115 V ac (103,5 to 122) V ac / 230 V ac (207 to 243,8) V ac Models from 1,100 to 1,400 A: 230 V ac (207 to 243,8) V ac	
	Frequency	(50 to 60) Hz (+/- 10%), or (45 to 66) Hz	
Degree of protection	Metallic cabinet	IP20 from 10 A up to 30 A / IP 00 for 45 A and above	
Control	Control method	Motor voltage variation (three phase induction motor)	
	CPU	32 bits RISC microcontroller	
	Types of control	Voltage ramp	
		Current limitation	
		Current limitation ramp	
Pump control			
		Torque control 1.2 or 3 points	
Starting duty cycles	Rated	300% (3 x I nom.) during 30s for 3 cables connection and during 25s for 6 cables connection	
	Starts per hour	10 starts per hour for models from 10 A to 820 A 5 starts per hour for models from 950 A to 1,400 A	
Inputs	Digital	5 x 24 V dc insulated programmable inputs 1 x 24 V dc insulated programmable input for motor PTC	
	Relay	3 programmable outputs 250 V / 2 A: (2 x NA) + (1 x NO + NC - fault)	
Outputs	Analog	1 programmable output (11 bits) 0...10 V dc 1 programmable output (11 bits) 0...20 mA or 4...20 mA	
	Safety	Protections	Over voltage
Under voltage			Output phase loss (motor)
Voltage unbalance			Thyristor failure
Under current			CPU failure (watch dog)
Over current			Programming error
Current unbalance			Serial communication error
Overload (motor) - i ² t			Self-check error
Thyristors over temperature			HMI-SSW06 communication error
Motor over temperature / PTC			Starting time expired
Phase sequence failure			Fieldbus communication error
External fault			Serial communication error
Open bypass contact failure ¹⁾			Under voltage in the electronic board
Closed bypass contact failure ¹⁾			Frequency out of range
Over current in the bypass ¹⁾			
Under current before bypass closing ¹⁾			
Functions/resources	Standard	Removable human-machine interface with double display LED + LCD	
		Programming access password	
		HMI language selection: portuguese, english, spanish and german	
		Control type selection: voltage ramp, current limitation, current limitation ramp, pump control, kick start voltage and current	
		Local/ Remote operation selection	
		Self-checking and fault auto-reset	
		Oriented start-up according to the control type	
		Standard connection or Inside delta connection (not available for 690 V)	
		All protections and functions available in both types of connection to the motor	
		Pump control function (protection against water hummer in pumps)	
		Copy function (soft-starter -> HMI or HMI -> soft-starter)	
		Built-in bypass for the models 10 A to 820 A	
		Serial interface RS232 with Modbus-RTU protocol. RS485 optional	
		Insulated input for motor PTC	
		Standard or user parameters reset (brings back the standard or user values)	
		Special features: hours	
		Programmable over and undervoltage and voltage unbalance between phases	
		Programmable over and undercurrent and current unbalance between phases	
		Under and over current before bypass	
		Programmable immediate over and undercurrent	
		Programmable time for immediate over and undercurrent	
		Programmable interval between starts	
		Programmable line nominal voltage	
		Fully programmable voltage ramp	
		Programmable current limitation	
		Programmable current ramp	
		Programmable pump control	
Fully flexible torque control			
Auto reset of the programmable thermal memory			
Thermal class protection (motor overload) programmable from class 5 to 45			

SSW06 - Technical Data

Functions/resources	Standard	JOG function in both directions without auxiliary contactors
		SoftPLC programmable through USB port and WLP software
		Emergency start
		Multimotor application
		Optimal braking without auxiliary contactors
	Optional	Frame for remote HMI
		Cable to interconnect the soft-starter with the remote HMI 1, 2, 3 and 5 m
		RS485 communication kit
		Profibus-DP communication kit
		DeviceNet communication kit
Human-machine interface (HMI-SSW06-LCD)	Controls	Ethernet IP communication kit
		Pt-100 temperature transducer
	Supervision (read)	External current transformers
		IP20 protection for the models from 45 A up to 820 A
		Start, stop, reset and parameterization (main functions programming)
		Increase and decrease parameters and their values
		Motor current per phase (% soft-starter In)
		Motor current per phase (% motor In)
		Motor current per phase (A)
		Maximum starting current
		Average starting current
		Line frequency (0...99.9 Hz)
		Line voltage (0...999 V)
		Output voltage (0...999 V)
		Motor torque (% motor In)
		Load active power - (kW)
		Load apparent power - (kVA)
		Soft-starter status
		Digital and analogue inputs and outputs status
		Load cos (φ) - (0.00 - 0.99)
		Powered-up time hours
		Enabled hours operating time
		Soft-starter software version
		kWh hours monitoring
		Analog output monitoring
		SoftPLC status
		Storage of the 6 most recent faults and fault diagnostics
Motor thermal memory monitoring		
Fieldbus communication status		
Environment conditions	Temperature	Operating status
		0 to 55 °C (models from 10 to 820 A) standard operation at rated current
	Humidity	0 to 40 °C (models from 950 to 1,400 A) standard operation at rated current
		5...90 %, non condensation
Altitude	0...1,000 m: standard operation at rated current	
	1,000...4,000 m; with output current reduction of 1%/100 m, over 1,000 m	
Finishing painting	Color	Cover: opaque gray
		Cabinet: opaque blue
Standards	Safety	UL 508 standard - industrial control equipment ²⁾
	Low voltage	EN 60947-4-2 standard; LVD 73/23/EEC - low voltage directive
	EMC	EMC directive 89 / 336 / EEC - industrial environment
	UL (USA) / cUL (Canadá)	Underwriters laboratories Inc. - USA ²⁾
	CE (Europe)	Certified by EPCOS
	IRAM (Argentina)	Instituto Argentino de Normalización ²⁾
C-Tick (Australia)	Australian Communications Authority	

Notes: 1) Models from 85 A up to 820 A.

2) Models from 85 A up to 1,400 A approved, models from 10 A up to 60 A pending.

SSW06 - Coding

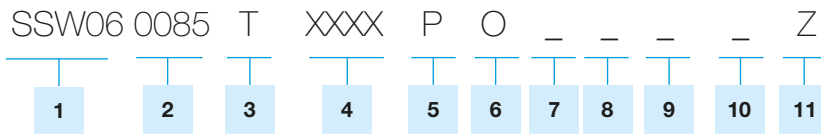

1 - WEG soft-starter SSW06 series

2 - Soft-starter rated output current

0010 = 10 A	0085 = 85 A	0365 = 365 A	0950 = 950 A
0016 = 16 A	00130 = 130 A	0412 = 412 A	1100 = 1,100 A
0023 = 23 A	00170 = 170 A	0480 = 480 A	1400 = 1,400 A
0030 = 30 A	0205 = 205 A	0604 = 604 A	
0045 = 45 A	0255 = 255 A	0670 = 670 A	
0060 = 60 A	0312 = 312 A	0820 = 820 A	

3 - Power supply:

T= three-phase

4 - Power supply voltage:

2257 = 220...575 V
5769 = 575...690 V

5 - Manual language:

P = portuguese
E = english
S = spanish

6 - Product version:

S = standard
O = with options

7 - Degree of protection (IP):

Blank = standard (see technical data table)

8 - Human-machine interface (HMI):

Blank = standard (with LED + LCD HMI)
SI = without HMI

9 - Special hardware:

Blank = standard
H1 = fan 115 V (950 A model)
H2 = fan 220 V (950 A up to 1,400 A model)

10 - Special software:

Blank = standard
S1 = optional with special software version

11 - Code end:

Z = end of coding

Notes: 1) Communication kits are optional.

2) From 950 A up to 1,400 A models the ventilation voltage must be defined (H1 or H2).

SSW07 and SSW08

The SSW07 and SSW08, with DSP (Digital Signal Processor) control were designed for high performance on motor starts and stops with an excellent cost-benefit ratio. Easy to set up, it simplifies start-up activities and daily operation. The SSW07 and SSW08 are compact optimizing space in electric panels. It already incorporates electric motor protection. It adapts to customer needs through its easy-to-install optional accessories. Thus, a keypad and a communication interface or a motor PTC input can be added to the product. The soft-starter SSW07 and SSW08 series has been developed on the matter of achieving the best cost-benefit ratio. The bypass built-in allows energy saving as well as increased soft-starter lifetime. The SSW07 and SSW08 are equipped with the same functionalities, being the SSW07 applied for heavy load starts and the SSW08 for light and moderate load starts.

Benefits

- Reduction of mechanical stresses over the coupling and transmission devices (gearboxes, pulleys, gears, conveyors, etc) during the start
- Increases motor and machine mechanical equipment lifetime due to the reduction of mechanical stress
- Easy operation, setup and maintenance
- Simple electrical installation
- Operates in environments up to 55 °C (without current reduction for all models)
- Integral, electronic motor protection
- Kick start function for starting high breakaway torque loads
- Reduces Water Hammer in pump applications
- Limitation of voltage drop during start
- Voltage range (220 to 575 V ac)
- Switched mode power supply with EMC filter for the control of electronics (110 to 240 V ac)
- Built-in bypass providing size reduction and energy saving
- Voltage monitoring of the electronics allows to backup I x t values (thermal image)

Certifications



Applications

SSW07

Applied for Heavy Loads

- Stone crusher
- Centrifuge
- Wood chipper
- Wood slicing machine
- Conveyor
- Axial and centrifugal fan
- Ball mill (ceramic)
- Hammer mill



SSW08

Applied for Light and Moderate Load

- Centrifugal pump
- Immersed centrifugal pump
- Blade vacuum pump
- Screw compressor
- Sieving machine



SSW07 and SSW08

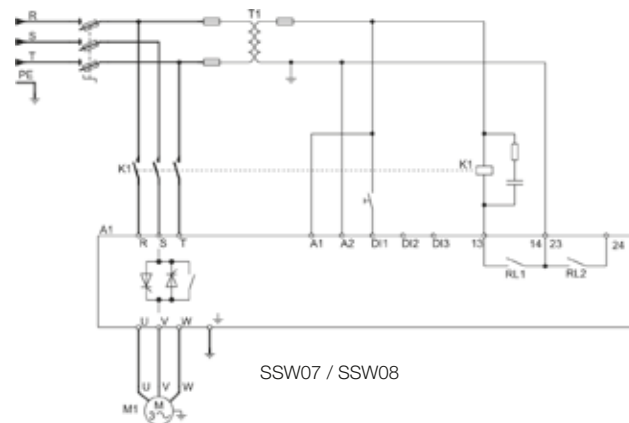

SSW07 / SSW08

Connections, Settings and Indications

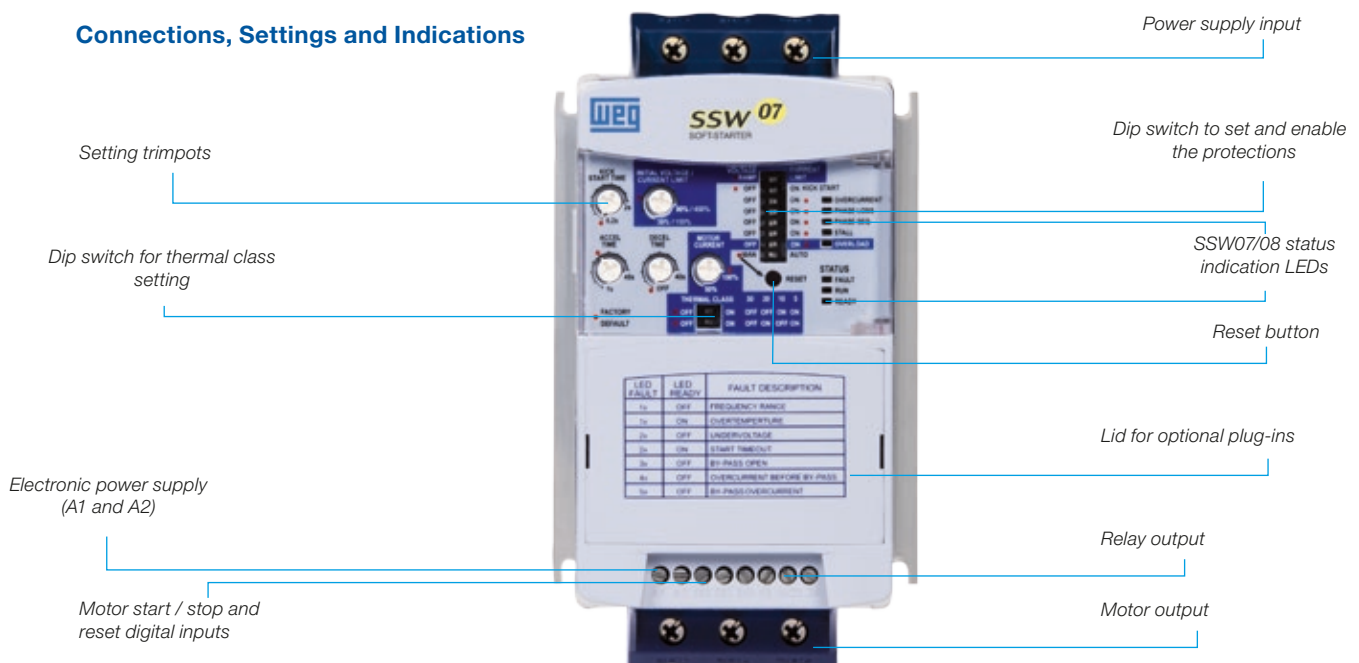

SSW07 and SSW08 - Accessories and Options

The SSW07 and SSW08 soft-starters can be communicated to Fieldbus communication network through the most common standard protocols in the world, as follows:

- Fieldbus →
- Profibus-DP (with MFW01)
 - DeviceNet (optional)
 - Modbus-RTU RS232 (optional)
 - Modbus-RTU RS485 (optional)

Mainly intended to integrate large automation plants, communication networks offer many advantages in the supervision, monitoring and on-line control of the soft-starters, providing high performance and great operational flexibility. To be connected to communication protocols, as Profibus-DP and DeviceNet, the SSW07 and SSW08 series offer plug-in accessories to install according to the desired protocol. For the Modbus-RTU protocol, the connection can be done via RS232 or RS485 (optional) interface.



SSW07 and SSW08 - Keypad

Operation interface with display, LED (7 segments), which allows excellent long distance visibility. The HMI with copy function built-in allows copy of certain user configuration from an existent soft-starter to others. It gives reliability for applications where the same parameters settings is desired for more than one soft-starter.

Local
Plug-in type HMI.



SSW07 and SSW08 local HMI

Remote
Remote HMI for placing at the panel door or machinery console.



SSW07 and SSW08 remote HMI
Cable for connecting HMI to SSW07 and SSW08.
Cable length: 1, 2, 3, 5, 7.5 and 10 m.

SuperDrive G2



Windows-based software, for SSW07 and SSW08 parameter setting, control and monitoring. The following functionalities are provided with the SuperDrive G2:

- SSW07 and SSW08 automatic identification
- SSW07 and SSW08 reading parameters
- On-line parameters settings for SSW07 and SSW08
- Off-line parameters settings to create a user application
- Easily accessible
- Supplied with a 3 m RS232 serial cable when the SuperDrive G2 software is acquired
- Free version available at WEG's website www.weg.net

SSW07 and SSW08 - Accessories



Modbus-RTU / RS232
Optional plug-in type module for Modbus-RTU communication in RS232



Modbus-RTU / RS485
Optional plug-in type module for Modbus-RTU communication in RS485



DeviceNet
Optional plug-in type module for DeviceNet communication



Profibus-DP
Via MFV-01/PD



IP20 Kit
For models from 130 A to 412 A, this kit guarantees protection against contact with energized parts



Cable for Connecting RS232. Cable length in 3 and 10 m



Motor PTC
Optional module for motor PTC connection



Ventilation Kit
For models from 45 A to 200 A, recommended for heavy loads with more than 3 starts per hour

SSW07 and SSW08 Control Methods

All settings necessary for starting any type of load is available through trimpots and dip switches.

Voltage Ramp

Allows smooth acceleration and/or deceleration, through voltage ramps.

Current Limit

Allows the setting of current limit during acceleration.

Voltage Kick Start

It enables an initial voltage pulse which provides on initial starting torque increase. This is required for starting high breakway torque loads.

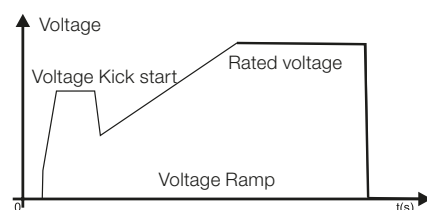
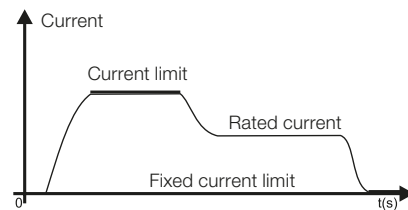
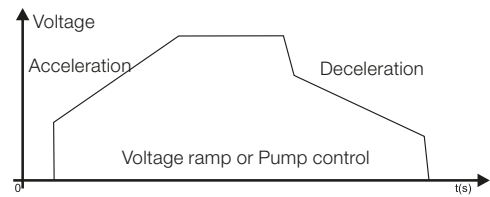

Built-In Bypass

Both SSW07 and SSW08 Series have built-in bypass to minimize power losses and heat dissipation in the thyristors, providing size reduction and contributing to energy saving. This is available in all models.

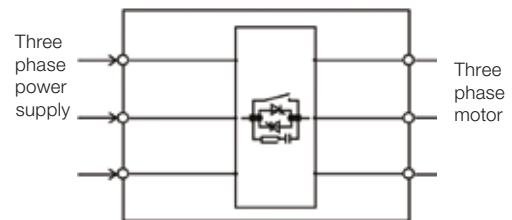

SSW07 and SSW08 - Drive Ratings

The tables below present the expected motor power for each soft-starter model under light load application (e.g.: centrifugal pump). However, for the proper selection of soft-starters, please use the SDW software.

Use the motor power ratings below only as a guidance. Motor rated currents may vary with speed and manufacturer.

IEC motor powers are based on WEG 4-pole motors; NEMA motor powers are based on NEC table 430-150.

Motor Voltages Between 220 V and 575 V

SSW model		Rated current	IEC - 50 Hz			IEC - 60 Hz		NEMA - 60 Hz		
			220 V 230 V	380 V 415 V	525 V	220 V 230 V	440 V 460 V	230 V	460 V	575 V
			A	kW	kW	kW	HP	HP	HP	HP
SSW07/08	0017T5	17	4	7.5	11	6	12.5	5	10	15
SSW07/08	0024T5	24	5.5	11	15	7.5	15	7.5	15	20
SSW07/08	0030T5	30	7.5	15	18.5	10	20	10	20	25
SSW07/08	0045T5	45	11	22	30	15	30	15	30	40
SSW07/08	0061T5	61	15	30	37	20	40	20	40	50
SSW07/08	0085T5	85	22	45	55	30	60	30	60	75
SSW07/08	0130T5	130	37	55	90	37	100	50	100	125
SSW07/08	0171T5	171	45	90	110	60	125	60	125	150
SSW07/08	0200T5	200	55	110	132	75	150	75	150	200
SSW07/08	0255T5	255	75	132	185	100	200	100	200	250
SSW07/08	0312T5	312	90	160	220	125	250	125	250	300
SSW07/08	0365T5	365	110	185	250	150	300	150	300	350
SSW07/08	0412T5	412	110	220	300	150	350	150	350	450

Note: the above maximum motor power ratings were calculated based on WEG models, 4 poles, IP55, standard, 55 °C ambient temperature.

SSW07 and SSW08

Dimensions and Weight

SSW model		Frame size	Dimensions mm (in)			Weight kg (lb)	Degree of protection	Inside delta connection	Internal bypass
			H	W	D				
SSW07/08	0017T5	1	162 (6.38)	95 (3.74)	157 (6.18)	1.3 (2.9)	IP20	No	Yes
SSW07/08	0024T5								
SSW07/08	0030T5								
SSW07/08	0045T5	2	208 (8.19)	144 (5.67)	203 (7.99)	3.3 (7.28)	IP00 (standard)	No	Yes
SSW07/08	0061T5								
SSW07/08	0085T5								
SSW07/08	0130T5	3	276 (10.9)	223 (8.78)	220 (8.66)	7.6 (16.8)	IP00 (standard)	No	Yes
SSW07/08	0171T5								
SSW07/08	0200T5								
SSW07/08	0255T5	4	331 (13.0)	227 (8.94)	242 (9.53)	9.2 (20.32)	IP20 (as optional)	No	Yes
SSW07/08	0312T5								
SSW07/08	0365T5								
SSW07/08	0412T5								

Mechanical Mounting

SSW model		Frame size	A mm (in)	B mm (in)	C mm (in)	D mm (in)	Mounting bolt
SSW07/08	0017T5	1	85 (3.35)	120 (4.72)	5 (0.20)	4 (0.16)	M4
SSW07/08	0024T5						
SSW07/08	0030T5						
SSW07/08	0045T5	2	132 (5.2)	148 (5.83)	6 (0.24)	3.4 (0.13)	M4
SSW07/08	0061T5						
SSW07/08	0085T5						
SSW07/08	0130T5	3	208 (8.19)	210 (8.27)	7.5 (0.3)	5 (0.2)	M5
SSW07/08	0171T5						
SSW07/08	0200T5						
SSW07/08	0255T5	4	200 (7.87)	280 (11.0)	15 (0.59)	9 (0.35)	M8
SSW07/08	0312T5						
SSW07/08	0365T5						
SSW07/08	0412T5						

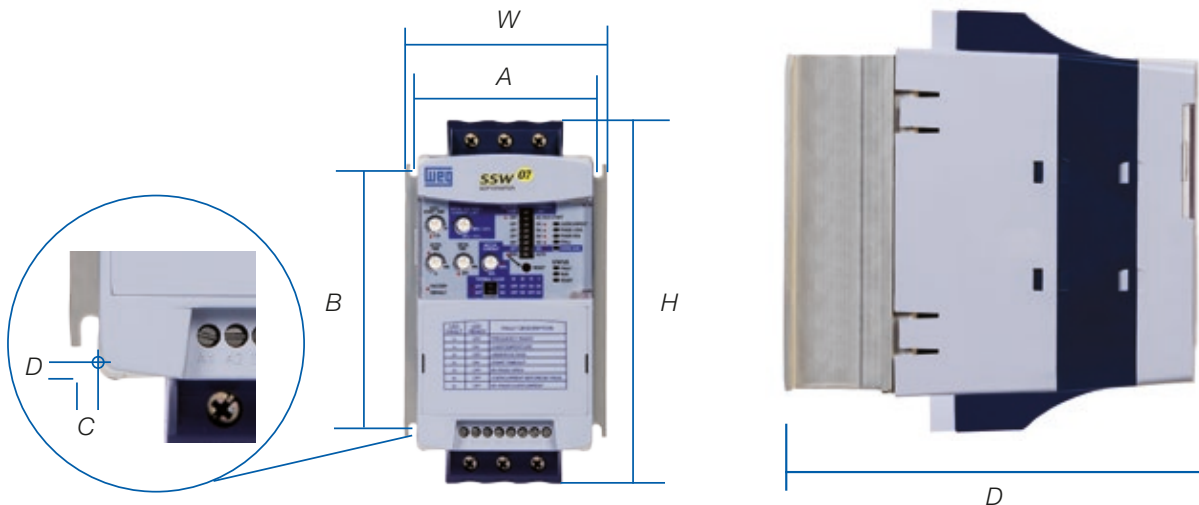

SSW07 and SSW08 - Technical Data

Power supply	Power	220 to 575 V ac		
	Control	110 to 240 V ac (-15% to +10%)		
	Frequency	50 to 60 Hz (+/- 10%)		
Degree of protection	Injected molded plastic case	IP20 in models from 17 to 85 A		
		IP00 in models from 130 to 412 A (IP20 as optional)		
Control	Control method	Motor voltage variation		
	CPU	DSP type microprocessor (Digital Signal Processor)		
	Types of control	Voltage/current ramp	Pump control	
Current limit		Direct on-line start (DOL)		
Starting duty cycle	Frame size 1 and 4	SSW07 with 3 x In during 30s, 10 starts per hour SSW08 with 3 x In during 20s, 10 starts per hour		
	Frame size 2 and 3	SSW07 with 3 x In during 30s, 3 starts per hour SSW08 with 3 x In during 20s, 3 starts per hour (availability of ventilation kit for applications where 10 starts per hour is demanded)		
Inputs	Digital	3 isolated programmable inputs		
Outputs	Relay	02 relays with NO contacts, 240 V ac, 1 A, programmable functions		
Safety	Protections (standard)	Overcurrent	Locked rotor	
		Overcurrent before bypass	Excess starting time	
		Phase loss	Frequency outside tolerance	
		Inverted phase sequence	Bypass contact open	
		Overtemperature in power heatsink	Undervoltage in control supply	
	Protections (with accessory)	Motor overload (class 5 to 30)		
		Undercurrent	Programming error	
		Current imbalance	Serial communication error	
		Undercurrent before bypass	HMI communication error	
		External fault	Overtemperature in motor PTC	
Functions / resources	Standard	Voltage ramp (Initial voltage: 30% to 90%)		
		Current limitation (150% to 450% of rated current)		
		Starting time (1 to 40s)		
		Kick start (Off - 0.2 to 2s)		
		Deceleration ramp (0 to 40s)		
		Motor and SSW07 current relation (50% to 100%)		
		Faults auto-reset		
		Thermal memory auto-reset		
		Factory standard reset		
		Soft-starter built-in bypass		
Programming accessory (HMI or serial communication)	Command	On, off / reset and parameterization (function programming)		
	Additional functions / resources	Starting time up to 999s		
		Deceleration time up to 240s		
		Program enabling password		
		Selection for local / remote operation		
		Copy function (SSW07/08 >>> HMI and HMI >>> SSW07/08)		
	Supervision (reading)	Programmable rated voltage		
		Motor current (%soft-starter In)		
		Motor current (%motor In)		
		Motor current (A)		
		Current indication in each phase R-S-T		
		Supply network frequency		
		Apparent power supplied to load (kVA)		
		Soft-starter status		
		Digital input and output status		
Last 4 faults				
Accessories and options	Options	Plug-in type local HMI		
		HMI remote kit		
		1, 2, 3, 5, 7.5 and 10 m cable for remote HMI interconnection		
		RS232 communication kit		
		SSW-07/08 interconnection cables>>> PC Serial (RS232) 3 and 10m		
		RS485 communication kit		
		Motor PTC kit		
		Ventilation kit for size 2 (45 to 85 A)		
		Ventilation kit for size 3 (130 to 200 A)		
		IP20 kit for sizes 3 and 4 (130 to 412 A)		
Finishing	Color	Lid: Gray Ultra Mat		
		Cabinet: Blue Ultra Mat		
Conformities / standards	Safety	UL 508 Standard - Industrial Control Equipment		
	Low voltage	EN 60947-4-2;LVD 2006/95/EC Standard - Low voltage Directive		
	EMC	EMC 89/336/EEC Directive - Industrial Environment		
	UL (USA) / cUL (Canada)	Underwriters Laboratories Inc. - USA		
	CE (Europe)	Conformity test conducted by EPCOS		
	C-Tick (Australia)	Australian Communication Authority		

SSW07 and SSW08 - Coding

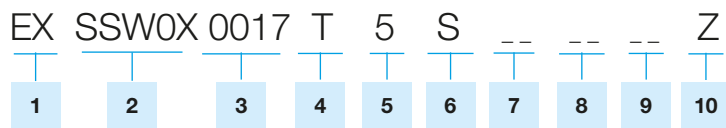

1 - Market / manual:

EX= export/english,
spanish and portuguese

2 - WEG SSW series soft-starters

07 = SSW07 series
08 = SSW08 series

4 - Soft-starter input power supply:

T = three-phase

5 - Power supply voltage:

5 = 220 to 575 V range

6 - Product version:

S = standard
O = with options

7 - Enclosure:

Blank = standard
IP = IP20 for models from
130 A to 412 A

8 - Special hardware:

Blank = standard
H1= electronic supply 110 to 130 V ac
H2= electronic supply 208 to 240 V ac
(the both codes for frame size 4)

9 - Special software:

Blank = standard

10 - End of code:

Z = end of coding







SSW07



SSW08

WEG Soft-Starter Comparison

		SSW05	SSW08	SSW07	SSW06
					
Power supply		220 to 460 V 460 to 575 V (-15 to +10%)	220 to 575 V (-15 to +10%)	220 to 575 V (-15 to +10%)	220 to 575 V (-15 to +10%)
Electronic power supply		90 to 250 V ac	110 to 240 V ac (-15 to +10%)	110 to 240 V ac (-15 to +10%)	110 to 240 V ac (-15 to +10%)
Power rating	HP	0.75 to 75	5 to 450	5 to 450	3 to 2650
	kW	0.55 to 55	4 to 300	4 to 300	2.2 to 1,950
	Current (A)	3 to 85	17 to 412	17 to 412	10 to 1,400
Enclosure		IP20	IP20 from 17 to 85 A IP00 from 130 to 412 A (IP20 as optional)	IP20 from 17 to 85 A IP00 from 130 to 412 A (IP20 as optional)	IP20 from 10 to 30 A IP00 from 45 to 1,400 A (IP20 as optional)
Typical loads		Light loads	Light and moderate loads	Heavy loads	Heavy loads
Inside delta connection (6 leads)		No	No	No	Yes
Control type	Voltage ramp	Yes	Yes	Yes	Yes
	Current limit	No	Yes	Yes	Yes
	Current limit ramp	No	No	No	Yes
	Pump control	No	Yes	Yes	Yes
	Torque control (1, 2, and 3 points)	No	No	No	Yes
Starting duty cycle	Number of starts per hour	4	10 ²⁾	10 ²⁾	10 (10 to 820 A) 5 (950 to 1,400 A)
	Normal thermal overload	300% - 10s	300% - 20s	300% - 30s	300% - 30s (Standard Connection) 300% - 25s (Delta Connection)
	Heavy thermal overload ³⁾	-	450% - 20s	450% - 30s	450% - 30s (Standard Connection) 450% - 25s (Delta Connection)
Inputs	Digital	2	3	3	5 11 ¹⁾
	PTC	No	Yes ¹⁾	Yes ¹⁾	Yes
	Pt-100	No	No	No	Yes ¹⁾
Outputs	Relay	2	2	2	3 9 ¹⁾
	Analog (0...10 V) or (0/4...20 mA)	No	No	No	2
Features / functions	Built-in bypass	Yes	Yes	Yes	Yes (up to 820 A)
	Kick start	No	Yes	Yes	Yes
	DC braking	No	No	No	Yes
	Optimal braking	No	No	No	Yes
	JOG	No	Yes	Yes	Yes
	Copy HMI	Yes	Yes	Yes	Yes
Protection	Over / under voltage	No	No	No	Yes
	Voltage unbalance	No	No	No	Yes
	Over / under current	Yes ¹⁾	Yes	Yes	Yes
	Current unbalance	No	Yes ¹⁾	Yes ¹⁾	Yes
	Thyristor overheating	No	Yes	Yes	Yes
	Motor overload	Yes	Yes	Yes	Yes
	Inverted phase sequence	Yes	Yes	Yes	Yes
	External fault	Yes	Yes ¹⁾	Yes ¹⁾	Yes
	Thyristor overload	Yes	No	No	No
	Power supply phase loss	Yes	Yes	Yes	Yes
	Motor phase loss	Yes	Yes	Yes	Yes
	Frequency out of range	Yes	Yes	Yes	Yes
	Fire mode	No	Yes	Yes	Yes
Standard setting	Trim pots and dipswitch	Yes	Yes	Yes	No
	HMI	Yes ¹⁾	Yes ¹⁾	Yes ¹⁾	Yes
	SuperDrive	SuperDrive	SuperDrive G2	SuperDrive G2	SuperDrive G2
Communication	Serial RS232	Yes	Yes ¹⁾	Yes ¹⁾	Yes
	Modbus-RTU	Yes ¹⁾	Yes ¹⁾	Yes ¹⁾	Yes
	Profibus-DP	Yes ¹⁾	Yes ¹⁾	Yes ¹⁾	Yes ¹⁾
	DeviceNet	Yes ¹⁾	Yes ¹⁾	Yes ¹⁾	Yes ¹⁾
	Ethernet IP	No	No	No	Yes ¹⁾
	USB port	No	No	No	Yes
Ambient conditions	Temperature	0 °C to 55 °C Rated current (In)	0 °C to 55 °C Rated current (In)	0 °C to 55 °C Rated current (In)	0 °C to 55 °C Rated current (10 to 820 A) 40 °C to 55 °C with current reduction (950 to 1,400 A)
	Humidity	0...90% without condensation	5...90% without condensation	5...90% without condensation	0...90% without condensation
	Altitude	0 to 1,000 m: rated conditions 1,000 to 4,000 m: with 1% current reduction for each 100 m above 1,000 m			

Notes: 1) Optional.
2) With 45 to 200 A ventilation kit.
3) With current derating.

WEG Worldwide Operations

ARGENTINA

WEG EQUIPAMIENTOS
ELECTRICOS
San Francisco - Cordoba
Phone: +54 3564 421 484
info-ar@weg.net
www.weg.net/ar

WEG PINTURAS - Pulverlux
Buenos Aires
Phone: +54 11 4299 8000
tintas@weg.net

AUSTRALIA

WEG AUSTRALIA
Victoria
Phone: +61 3 9765 4600
info-au@weg.net
www.weg.net/au

AUSTRIA

WATT DRIVE - WEG Group
Markt Piesting - Vienna
Phone: +43 2633 404 0
watt@wattdrive.com
www.wattdrive.com

BELGIUM

WEG BENELUX
Nivelles - Belgium
Phone: +32 67 88 84 20
info-be@weg.net
www.weg.net/be

BRAZIL

WEG EQUIPAMENTOS ELÉTRICOS
Jaraguá do Sul - Santa Catarina
Phone: +55 47 3276-4002
info-br@weg.net
www.weg.net/br

CHILE

WEG CHILE
Santiago
Phone: +56 2 784 8900
info-cl@weg.net
www.weg.net/cl

CHINA

WEG NANTONG
Nantong - Jiangsu
Phone: +86 0513 8598 9333
info-cn@weg.net
www.weg.net/cn

COLOMBIA

WEG COLOMBIA
Bogotá
Phone: +57 1 416 0166
info-co@weg.net
www.weg.net/co

ECUADOR

WEG ECUADOR
Quito
Phone: 5144 339/342/317
wegecuador@weg.net
www.weg.net/ec

FRANCE

WEG FRANCE
Saint Quentin Fallavier - Lyon
Phone: +33 4 74 99 11 35
info-fr@weg.net
www.weg.net/fr

GERMANY

WEG GERMANY
Kerpen - North Rhine Westphalia
Phone: +49 2237 9291 0
info-de@weg.net
www.weg.net/de

GHANA

ZEST ELECTRIC GHANA
WEG Group
Accra
Phone: +233 30 27 664 90
info@zestghana.com.gh
www.zestghana.com.gh

INDIA

WEG ELECTRIC INDIA
Bangalore - Karnataka
Phone: +91 80 4128 2007
info-in@weg.net
www.weg.net/in

WEG INDUSTRIES INDIA

Hosur - Tamil Nadu
Phone: +91 4344 301 577
info-in@weg.net
www.weg.net/in

ITALY

WEG ITALIA
Cinisello Balsamo - Milano
Phone: +39 02 6129 3535
info-it@weg.net
www.weg.net/it

JAPAN

WEG ELECTRIC MOTORS
JAPAN
Yokohama City - Kanagawa
Phone: +81 45 550 3030
info-jp@weg.net
www.weg.net/jp

MALAYSIA

WATT EURO-DRIVE - WEG Group
Shah Alam, Selangor
Phone: 603 78591626
info@wattdrive.com.my
www.wattdrive.com

MEXICO

WEG MEXICO
Huehuetoca
Phone: +52 55 5321 4231
info-mx@weg.net
www.weg.net/mx

VOLTRAN - WEG Group

Tizayuca - Hidalgo
Phone: +52 77 5350 9354
www.voltran.com.mx

NETHERLANDS

WEG NETHERLANDS
Oldenzaal - Overijssel
Phone: +31 541 571 080
info-nl@weg.net
www.weg.net/nl

PERU

WEG PERU
Lima
Phone: +51 1 209 7600
info-pe@weg.net
www.weg.net/pe

PORTUGAL

WEG EURO
Maia - Porto
Phone: +351 22 9477705
info-pt@weg.net
www.weg.net/pt

RUSSIA and CIS

WEG ELECTRIC CIS
Saint Petersburg
Phone: +7 812 363 2172
info-ru@weg.net
www.weg.net/ru

SOUTH AFRICA

ZEST ELECTRIC MOTORS
WEG Group
Johannesburg
Phone: +27 11 723 6000
info@zest.co.za
www.zest.co.za

SPAIN

WEG IBERIA
Madrid
Phone: +34 91 655 30 08
info-es@weg.net
www.weg.net/es

SINGAPORE

WEG SINGAPORE
Singapore
Phone: +65 68589081
info-sg@weg.net
www.weg.net/sg

SCANDINAVIA

WEG SCANDINAVIA
Kungsbacka - Sweden
Phone: +46 300 73 400
info-se@weg.net
www.weg.net/se

UK

WEG ELECTRIC MOTORS U.K.
Redditch - Worcestershire
Phone: +44 1527 513 800
info-uk@weg.net
www.weg.net/uk

UNITED ARAB EMIRATES

WEG MIDDLE EAST
Dubai
Phone: +971 4 813 0800
info-ae@weg.net
www.weg.net/ae

USA

WEG ELECTRIC
Duluth - Georgia
Phone: +1 678 249 2000
info-us@weg.net
www.weg.net/us

ELECTRIC MACHINERY

WEG Group
Minneapolis - Minnesota
Phone: +1 612 378 8000
www.electricmachinery.com

VENEZUELA

WEG INDUSTRIAS VENEZUELA
Valencia - Carabobo
Phone: +58 241 821 0582
info-ve@weg.net
www.weg.net/ve

For those countries where there is not a WEG own operation, find our local distributor at www.weg.net.



WEG Group - Automation Business Unit
Jaraguá do Sul - SC - Brazil
Phone: +55 47 3276 4000
automacao@weg.net
www.weg.net

